

ST-22001

3PCS - UTILITY WEDGE TOOL SET

- utility wedge set suitable for removal of wide range of exterior body and interior trim.
- composite material reduces marking or scratching paintwork body/ trim.
- contents:
 - 1pc - width 60mm x 196mmL.
 - 1pc - width 30mm x 190mmL.
 - 1pc - width 22mm x "U" notch blade x 265mmL.

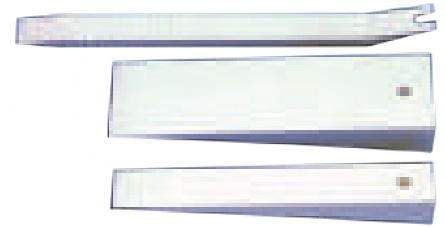

ST-22046

4PCS - SUPER SCRAPER SET

- working like chisel.
- tough plastic handle can be hitted with a hammer.
- sharpen when needed with a file.
- utility wedge set suitable for removal of wide range of exterior body and interior trim.
- contents:
 - 1pc - width 19 mm x 273 mmL.
 - 1pc - width 25 mm x 273 mmL.
 - 1pc - width 20 mm x 273 mmL.
 - 1pc - width 38 mm x 273 mmL.

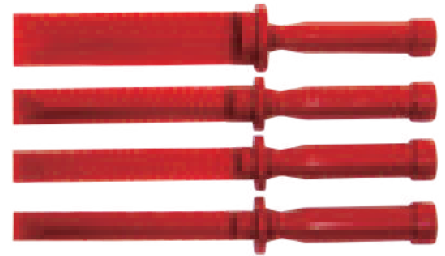

ST-22070

2PCS - SUPER SCRAPER SET

- working like chisel.
- tough plastic handle can be hitted with a hammer.
- sharpen when needed with a file.
- utility wedge set suitable for removal of wide range of exterior body and interior trim.
- contents:
 - 1pc - with handle: width 82mm x 290mmL.
 - 1pc - without handle: width 82mm x 165mmL.

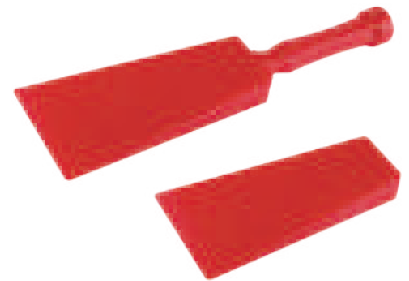

ST-22002

5PCS - HANDY REMOVER SET

- designed to simplify trim and trim stud removal.
- for resilient plastic to minimize panel damage and marking.
- upholstery clip: 10 x 20 mm "U" notch blade x 210 mmL.
- contents:
 - 1pc - pull remover: 31 mm "U" notch blade x 180 mmL.
 - 1pc - handy remover: 31 mm double "U" notch blade x 200 mmL.
 - 1pc - narrow remover: 13 x 13 x 175 mmL.
 - 1pc - wide remover: 61 x 61 x 160 mmL.

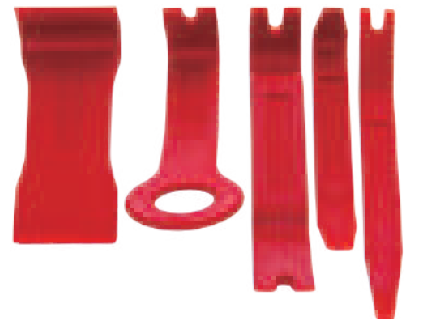

ST-22071

2PCS - HANDY REMOVER SET

- use this pry-style tool to create enough space to easily insert the air wedge without damaging the vehicle.
- contents:
 - 1pc - wedge-shaped handle, width 37mm x 226mmL.
 - 1pc - round-shaped handle, width 37mm x 252mmL.



ST-22065

2PCS - HOOK / WEDGE TOOL SET

- a high quality set of non-marring plastic trim removal tools.
- the universal hook tool features multiple profile for those tight spots which is difficult to fit in.
- the combination wedge tool is excellent for lifting bezel edges, and for the removal of molded body trim pieces, w/out damaging.
- contents:
 - 1pc - width 23mm x 185mmL.
 - 1pc - width 26mm x 209mmL.



ST-22048

TRIM CLIP REMOVER

- for plastic fastener, place the tool under the edge of the door upholstery panel and insert it into the fastener as far as possible, then simply pry up.
- with comfortable handle.



ST-22043

TRIM CLIP REMOVER PLIER

- allow easy access and removal of those hard to reach clips on bumper cover, fender liner etc.
- features positive lift action without damage the clip or the surrounding area.
- simply insert the jaws under the clip and squeeze the plier on or remove the clip.



ST-22072

TRIM CLIP REMOVER PLIER

- straight type.
- designed for removal of push pin plastic body fasteners and clips with center locking pin.
- removes locking pin without damage to pin or anchor.
- available for 4-groove, 2-groove and O-groove.
- suitable: most of cars.

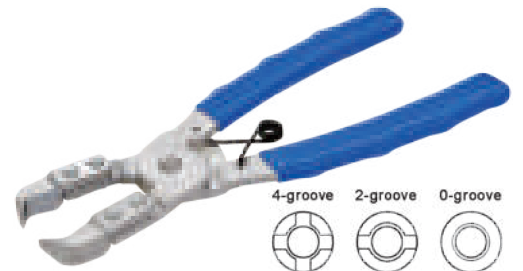

ST-22073

TRIM CLIP REMOVER PLIER

- angled type.
- designed for removal of push pin plastic body fasteners and clips with center locking pin.
- removes locking pin without damage to pin or anchor.
- available for 4-groove, 2-groove and O-groove.
- suitable: most of cars.

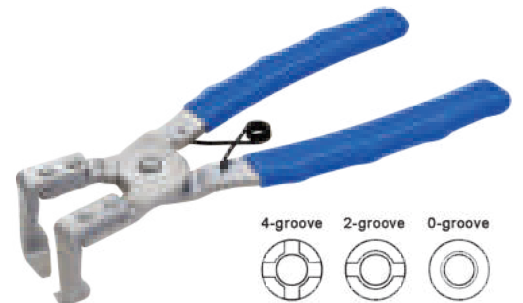

ST-22074

TRIM CLIP REMOVER PLIER

- straight type.
- designed for removal of push pin plastic body fasteners and clips with center locking pin.
- removes locking pin without damage to pin or anchor.
- available for 3-groove.
- suitable: nissan, infiniti, etc.



ST-22059

3PCS - STRAIGHT TYPE LIGHT-DUTY SCRAPER TOOL SET

- multiple using for delicate surface finish and close tolerance components.
- unique tips ensure the economic, consistent and aesthetic removal.
- control and precision during delicate assembly, repair or restoration work.
- flexible, durable and easy to use.
- non-marring material non-scratch.



ST-22060

3PCS - ANGLE TYPE LIGHT-DUTY SCRAPER TOOL SET

- multiple using for delicate surface finish and close tolerance components.
- unique tips ensure the economic, consistent and aesthetic removal.
- control and precision during delicate assembly, repair or restoration work.
- flexible, durable and easy to use.
- non-marring material non-scratch.



ST-22061

3PCS - LIGHT-DUTY PRYING / SMOOTHING TOOL SET

- prying apart electronic key fobs (battery replacement).
- prying dashboard parts and air vent.
- prying / smoothing epoxy, adhesives and silicone uniform.
- paint stripping in confined space.
- removing / installing O-ring and gasket.
- cleaning small parts.
- flexible, durable and easy to use.
- non-marring material non-scratch.

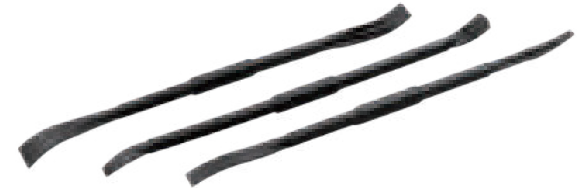

ST-22062

3PCS - LIGHT DUTY O-RING REMOVAL TOOL SET

- removing / manipulating O-ring, small seal / gasket, clip.
- cleaning air vent assembly.
- handling delicate wiring, composite electrical connectors.
- to reach access panels.
- cleaning tight gaps in interior components.
- flexible, durable and easy to use.
- non-marring material non-scratch.

**WIRE INSTALLATION TOOL**

ST-25081A overall length: 730mm.

ST-25081B overall length: 1.000mm.

ST-25081C overall length: 1,500mm.

- designed for quick installation of wires for stereo systems, alarm system cellular phones, vacuum hoses and air shock supply lines.
- conical shaped collet provides secure wire retention when threading wires.
- will push or pull wires through openings.



ST-25004

36PCS - FOLDING-TYPE RADIO REMOVAL TOOL SET

- the ultimate vehicle radio removal tool set for stereo installer and DIY to remove a wide variety of vehicle's radios & stereos.
- suitable for:
Mercedes / Becker / VW / Audi / Porsche / Sköda-New / Becker-New / PK-Clarion / RK-Kenwood 01 / Sony / RK-Kenwood / Sony / RK-Kenwood / Fiat Brava / JVC / Pioneer / Panasonic 2006 / Panasonic / Sony II ab 2002 / Opel / Grundig / Ford / Blaupunkt.



ST-25001

52PCS - RADIO REMOVAL TOOL KIT

- the ultimate vehicle radio removal tool set for stereo installer & DIY to remove a wide variety of vehicle's radios & stereos.
- suitable for:
Ford / VW / Audi / Grundig / Blaupunkt / BMW / Mercedes / Porsche / Opel / New Beckers / New Blaupunkt / New Sköda / Fiat Brava / doppel kuge linbus / Kenwood 2002 / Kenwood III / Sony II ab 2002 / Kenwood III ab 2002 / Pioneer / JVC / Sony Ibis 2001 / Kenwood Ibis 1998 / Panasonic / Kenwood New / Clarion- New / Clarion-Alt / Panasonic 2006 / Sony IDIC 2005



ST-22016

12PCS - AIR BAG REMOVAL TOOL KIT

- set includes updated special tools for a variety of applications.
- 1999~2004 new body style VW, Passat, Jetta, Golf & Beetle.
- VW, Passat B5, Polo, Lupo, Audi A4 & A6, Sköda superb.
- VW Golf 4, New Beetle, Seat, Sköda Fabia, Octavia AB (BJ1999).
- VW Golf 4, VW-Passat AB (BJ1998~2004), Bora AB (BJ.1999).
- 1/4" star tamper socket bit T30H - Mercedes, Ford, Opel, U.S.W.
- 1/4" star socket bit T30 - Mercedes and BMW.
- 1/4" star tamper socket bit T25H - Mercedes and BMW.
- VW modelle U.A. Passat, AB (BJ.2000).
- 1/4" hex socket bit H5 - Mercedes, Audi.
- 1/4" star socket bit T25 - Passat, AB
- suitable for the fast and safe removal of steering wheel airbag.

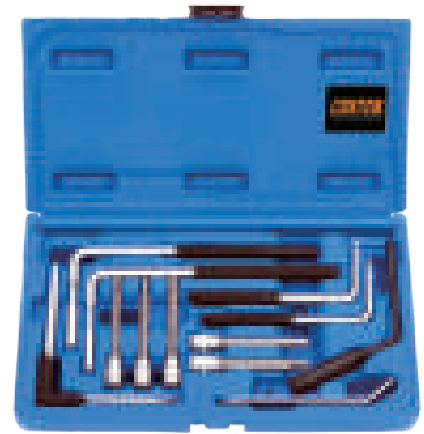

ST-25078

5PCS - TERMINAL RELEASE TOOL SET

- easily to remove terminal from electrical connector.
- large, high polished chrome handle with knurled finish.
- sturdy stainless steel tips.
- to fit the most vehicles asian.
- contents:
 - 1pc - single face blade tool: 1.0 mm (w.) x 1.0 mm (t.) tip.
 - 1pc - dual face blade tool: 1.5 mm (w.) x 1.0 mm (t.) tip.
 - 1pc - single face blade tool: 1.8 mm (w.) x 1.0 mm (t.) tip.
 - 1pc - ladder blade tool: 1.5 mm (w.) x 0.3 mm (t.) tip.
 - 1pc - knife blade tool: 2.0 mm (w.) x 0.8 mm (t.) tip.
- application:
 - Acura / Honda / Toyota / Mitsubishi / Lexus / Nissan / Infiniti.



ST-25082

3PCS - CONNECTOR AND TERMINAL REMOVAL TOOL KIT

- these tools are designed specifically for removing connectors and releasing terminals of the VAG vehicles.
- removing most of VW / Audi / Porsche push and pull style connectors. MAF
- removing MAF sensor, coil pack, headlight, fog light, level sensor, MAP sensor and etc...
- releasing terminals of VW / Audi / Porsche junior and micro connectors.



ST-25079

12PCS - UNIVERSAL TERMINAL RELEASE TOOL SET

- easily to remove terminal from electrical connector.
- sturdy stainless steel tips.
- ejection tools for contact size 1.5 or 3.5mm (dia.) w/dismantling sleeves for contact sizes and application: BMW, Daimler Chrysler, Fiat, Man, Porsche, Opel, Seat, Sköda, VW and Audi.
- ejection tools for contact size 2.3mm (dia.) w/dismantling sleeves for contact sizes and application: Ford, Opel, Psa, Renault.
- cable extractor tool for plugs with one release channel 2.8 and 5.8mm and application: BMW, Daimler Chrysler, Ford, Man, Opel, Porsche, Psa, Renault, Seat, Sköda, VW and Audi.
- cable extractor tool for micro-timer II, III contacts 1.6mm (dia.) & application: Daimler Chrysler, Opel, Porsche, Psa, Renault, Saab, Seat, Sköda, VW/Audi.
- cable extractor tool for maxi-power timer contact 9.5mm (dia.) & application: Daimler Chrysler, VW and Audi.
- cable extractor tool for pit-pod contacts and application: all vehicle makes.
- cable extractor tool for micro-timer I contact & ABS plug-in housing 1.6mm (dia.) & application: Fiat, Ford, Mazda, Opel, Psa, Renault, Saab, VW/Audi.
- cable extractor tool for plugs with two release channels 2.8 & 5.8mm (dia.) and application: BMW, Daimler Chrysler, Fiat, Ford, Man, Opel, Psa, Renault, Saab, VW and Audi.



ST-25080

14PCS - TRUCK TERMINAL RELEASE TOOL SET

- available with Man / Volvo / Scania / Iveco and most trucks.
- easily to remove terminal from electrical connector.
- sturdy stainless steel tips.
- ejection tools for contact size 1.5 or 3.5mm (dia.) w/dismantling sleeves for contact sizes and application: BMW, Daimler Chrysler, Fiat, Man, Porsche, Opel, Seat, Sköda, VW and Audi.
- ejection tools for contact size 4.0mm (dia.) (ABS) w/dismantling sleeves for contact sizes and application: Daimler Chrysler trucks, Man, Scania.
- ejection tools for contact size 4.0mm (dia.) w/dismantling sleeves for contact sizes and application: Daimler Chrysler trucks, Man, Scania.
- assembly sleeve (ABS) and application: Daimler Chrysler trucks, Man, Scania.
- cable extractor tool for plugs with one release channel 2.8 and 5.8mm (dia.) and application: BMW, Daimler Chrysler, Ford, Man, Opel, Porsche, Renault, Psa, Seat, Sköda, VW and Audi.
- for flat plug-in sockets with single latch (flat plug without box) and application: Man.
- for flat plug-in sockets, VKR box contacts and application: Man.
- for flat plug-in sockets, MKR/MKS contacts, and application: Man, Volvo.
- cable extractor tool for plugs with two release channels 2.8 & 5.8mm (dia.) and application: BMW, Daimler Chrysler, Fiat, Ford, Man, Opel, Psa, Renault, Saab, VW and Audi.



ST-25085

9PCS - STEERING WHEEL & FLY WHEEL PULLER SET

- specialized puller set for steering wheel, pulley and fly wheel puller.
- can also be used as a two or three way puller to remove pulleys and flywheel from small engines and snowmobiles.
- works on most vehicle.
- contents:
 - 1pc - forcing screw: 10.9 mm (dia.) - 12T x 125mmL.
 - 2pc - screw: 5/16" - 24NF x 75mmL.
 - 2pc - screw: 3/8" - 16NC x 75mmL.
 - 1pc - adaptor.
 - 2pc - screw: 5/16" - 18NC x 90mmL.
 - 1pc - yoke.

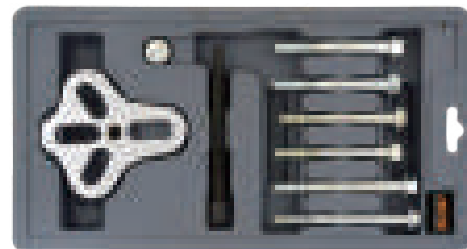

ST-24524

18PCS - STEERING WHEEL & HARMONIC BALANCE PULLER SET

- specialized puller set for steering wheel, pulley and fly wheel puller.
- can also be used as a two or three way puller to remove pulleys and flywheel from small engines and snowmobiles.
- the most complete harmonic balancer puller.
- designed to ease the operation of pulling the balancer pulley.
- reduces damage to both pulley and shaft.
- works on most vehicle.
- contents:
 - 1pc - forcing screw: 10.9 mm (dia.) - 12T x 125mmL.
 - 1pc - forcing screw: 15.5 mm (dia.) - 11T x 140mmL.
 - 2pc - screw: 5/16" - 24NF x 75mmL.
 - 3pc - screw: 3/8" - 16NC x 75mmL.
 - 2pc - screw: 3/8" - 16NC x 75mmL.
 - 2pc - yoke.
 - 2pc - screw: 5/16" - 18NC x 90mmL.
 - 2pc - adaptor.
 - 3pc - screw: 3/8" - 24NF x 75mmL.

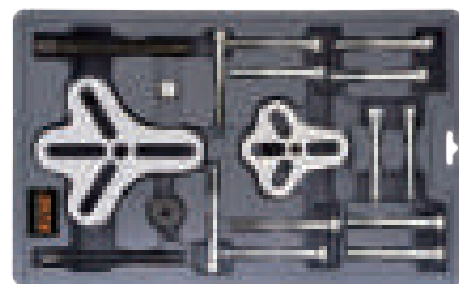

ST-25092

STEERING WHEEL LEVEL

- the steering wheel level is a sturdy and simple tool used to assure a level steering wheel during a front-end alignment procedure.
- the tool easily attached to the steering wheel at the beginning of the alignment procedure.
- it is spring-loaded for automatic centering and self-retaining.
- suitable for inside diameter of steering wheel from 154 ~ 355mmL.



ST-22035

SINGLE SUCTION CUP

- this pliable rubber suction cup creates enough suction to move an 40 kgs object, pull a dent out of your fender or pick up a large piece of plate glass.
- features include a durable high-impact nylon body and a squeeze release on the handle for added convenience.
- this durable suction cup is perfect for the home garage & auto shop alike.
- cup dia.: 115 mm.
- loading capacity: 40 kgs.



ST-22036

3PCS - DOUBLE SUCTION CUP SET

- each suction cup set contents two suction cups & one ratchet tie down.
- the most helpful tool in moving, use suction cup to move or install object / materials so easy that can operate one person.
- unique design of adjustable suction cup to increase the adhesive function.
- application for mobile, stone, glass industry, flat window, windshield, glass, marble, granite, plastic, metal, tiles, decorative surfaces...
- ratchet tie-down: 1" x 360 cmL.
- cup dia.: 115 mm.
- loading capacity: 160 kgs.



ST-22014

14PCS - WINDSCREEN REMOVING TOOL KIT

- this is a master kit for cutting the vinyl adhesive compound and urethane around the windshield and auto glass.
- 3pc - pinch weld scraper: 3/4" - 5/8" & 1/2" wide.
- 1pc - 24" weather strip cutting knife.
- 1pc - windshield molding release tool.
- 1pc - 12" weather strip cutting knife.
- 1pc - wide pinch weld scraper.
- 1pc - windshield removal wrench.
- 2pc - wire gripping handle.
- 1pc - 72 feet triangle wire.
- 1pc - wire feeder tool.
- 1pc - trim pad remover.
- 1pc - hex. head wrench.



ST-22078

9PCS - WINDSCREEN REMOVING TOOL KIT

- this is a master kit for cutting the vinyl adhesive compound and urethane around the windshield and auto glass.
- this set consists of the following:
 - 1pc - windscreen removal tool-cuts the adhesive around the screen.
 - 1pc - wire feeder tool-designed for easy & flexible insertion of wire through polyurethane, allowing speedy removal of bonded windscreen.
 - 1pc - double direction moulding release tool.
 - 1pc - braided wire (3 strand).
 - 2pc - wire gripping handles.
 - 1pc - trim pad remover.
 - 2pc - cold knife blade.



ST-22039

4PCS - WINDSCREEN REMOVING TOOL SET

- useful for removing the windshield of most vehicles.
- complete tool kit for the removal of bonded and rubberized screen.
- reinforced composite handle with heat treated carbon shaft.
- 1pc - stainless steel wire roll 0.6 x 0.6 mm x 50 mL. (ST-22039A)
- 1pc - wire T-handle.
- 1pc - wire guide.
- 1pc - wire needle.



ST-22079

INSTALL CHANNEL - TYPE MOULDINGS TOOL

- the tool has a nylon roller that is pulled against the moulding.
- this action seats the butyl against the glass so the moulding will stay in place.
- it has a clear acrylic roller attachment that lets you see through the tool and make sure you are seating the rubber properly.



ST-22047

WINDSCREEN WIPER-ARM REMOVER TOOL

- this wiper arm remover tool is the ideal tool to remove stuck on windscreen wiper arms.
- avoid to damage the vehicle bodywork or wiper assembly.
- the design allows the tool to be fastened securely to the wiper arm before commencing the pull.
- the "U" shape ensures a perfect hold, pulling the wiper arm squarely off every time.



ST-22069

5PCS - WINDSCREEN WIPER-ARM REMOVER TOOL SET

- remove wiper arms in an energy-saving manner.
- universal application for both front and rear wiper arms.
- include 4 cup pullers and 1 extractor.
- extractor puller is specially designed for confined areas as the legs can be inserted from different angles.



ST-22051

16PCS - UNIVERSAL WINDSCREEN WIPER-ARM PULLER KIT

- this set designed to remove bolted windscreen wiper arm, especially for those which have become rusted or corroded onto the drive-shaft.
- contents:

	1pc - drive.
1pc - hollow-cap.	2pc - special-legs.
1pc - puller.	8pc - grippers.
1pc - spindle-cap.	1pc - spindle-extend.
- application:
Audi / Alfa-Romeo / BMW / Chrysler-Jeep / Citroën / Chevrolet-Daewoo / Daihatsu / Fiat / Ford / Honda / Saab / Hyundai / Jaguar / Kia / Land Rover / Mazda / MG / Rover / MB / Mitsubishi / Nissan / Opel / Peugeot / Porsche / Renault / Seat / Skoda / Smart / VW / Toyota / Volvo / Suzuki.



ST-22015

6PCS - HAND PUMP WITH INFLATABLE PAD SET

- this set allows the easy, problem-free and precise positioning, fixing and dismantling of body parts, interior trim, etc.
- the different shape of the 5 inflatable pad allows their application in the most different places and operating range.
- contents:

1pc - inflatable hand pump: 40 mm (dia.) x 460 mmL.
5pc - inflatable pad: 160x160, 190x55, 19x35, 325x120, 420x140mm.



ST-22037

2PCS - MINI SUCTION LIFTER SET

- ideal for small dent under 60mm in diameter.
- require surface area to grip to.
- lift sheet metal with a smooth surface.
- operate by closing the two handles together.
- durable hi-impact nylon body.
- quick release handle.
- cup dia.: 60 mm / each.
- loading capacity: 12 kg / each.



ST-22042

MINI PISTOL SUCTION LIFTER

- despite it's small dimension, it has an optimal seal, safety to support up to 15 kgs.
- created for the disassembly of lamps, tail lights, rearview mirror, lateral glass, etc.
- cup dia.: 70 mm.
- loading capacity: 15 kg.



ST-22056

MINI SUCTION LIFTER

- plastic suction cup prevents damaging the surface.
- designed for handling glass, tile, plastic, metal sheet and other non-porous materials.
- 55 mm (dia.) cup can be much-easier to pick-up the vehicles' head and tail light cover.
- loading capacity: 5.0 kg.



ST-22084

2PCS - MINI SUCTION LIFTER SET

- rubber gripper prevents to damage the surface.
- designed for handling glass, tile, plastic, metal sheet and other non-porous materials.
- 85 mm (dia.) cup can be much-easier to pick-up the vehicles' head and tail light cover.
- loading capacity: 20.0 kg / each.



ST-22066

2PCS - LIGHT COVER REMOVAL TOOL SET

- easily remove front and tail light covers without creating crack.
- universal application for light covers with clip, but not for those fixed with screws and nuts.
- slip-resistant handle provides secure gripping.
- plastic probes avoid creating scrape on light cover surface.



ST-22064

MINI BULB REMOVER / INSTALLER PLIER

- bulb plier suitable for bayonet, screw and wedge gasing.
- for removing miniature style bulb fitted to vehicle, boat, plane, arcade game, vending machine & a multitude of electronic device.
- cup type ends grip bulb and electronic component securely.
- great tool for those hard to reach bulb location.
- dipped handle for secure and safe use.
- scissor design for easy handling.



ST-22086

6/12/24V. CAR LIGHT TESTER CHECK

- for use on automotie fuse blocks, marine fuse blocks, light socket and trailer wiring.
- bright indicator bulb.
- durable construction.
- pointed probe for piercing wires.



ST-22038

6PCS - MINI SUCTION CLAMP SET

- secure the panel during preparation stage or while waiting for adhesive to set.
- non-marking, composite construction with adjustable reach and clamp.
- do not need to fix with hand for a long time and have the effect of stable fixation and adherence.
- cup dia.: 85 mm / each.
- loading capacity: 10 kgs / each.



ST-22030

UNIVERSAL LIFT SUPPORT CLAMP

- hold gas charged lift supports found on hood, tailgate, hatchback & trunk.
- securely holds weak lift supports in the extended position to allow access to the engine compartment or luggage area.
- aluminum body prevents damaging to the lift support.
- jaw capacity: 10.20mm.

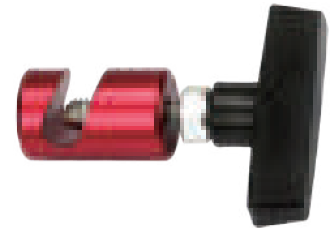

ST-22075

UNIVERSAL LIFT SUPPORT CLAMP

- hold gas charged lift supports found on hood, tailgate, hatchback & trunk.
- securely holds weak lift supports in the extended position to allow access to the engine compartment or luggage area.
- aluminum body prevents damaging to the lift support.
- jaw capacity: 13mm.

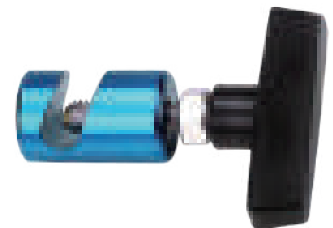

ST-22031

8PCS - PULL ROD KIT

- use for quick repair of dent and crease from outside the vehicle.
- these pull rods eliminate time consuming removal and replacement of upholstery, headliners and inner panel.
- set consists of four pull rods, two pick rod, one stainless steel straight edge, and one drill bit.

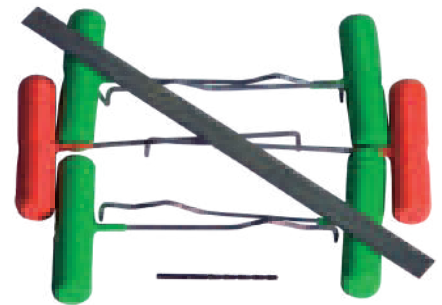

ST-22010

12PCS - DENT PULLER KIT

- quick assembly for applying hook-up on fender, bumper end, rocker panel, aligning door and door edge, hood and hood hinge, trunk and trunk hinges, headlights and more applications.
- 2pc - pipe dia. 22.5 x 590 mmL. / 22.5 x 200 mmL.
- 5pc - plates 6x170mm/6x120mm/3x100mm/ 6x200mm/6x200mm.
- 1pc - two hole pipe dia. 29 x 40 mm.
- 1pc - hammer 4.5kg cast iron. 1pc - hex nut 29 mm.
- 1pc - chain & hook. 1pc - dent puller.

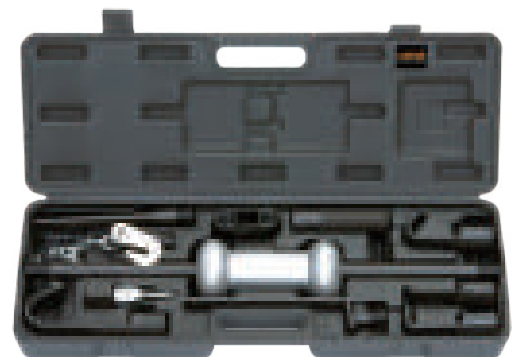

ST-22082

5PCS - PNEUMATIC DENT PULLER SET

- sliding hammer to ease dent without damaging to the paint surface.
- get the power and versatility of a slide hammer without marring the finish by welding or drilling body panels.
- pneumatic control creates a super-strong vacuum making it easy to pull most dents out of panels.
- instantly removes most dents without damaging paint.
- requires air compressor - no drilling, welding or sanding required.
- 3pc - suction pad 75, 100 and 125mm (dia.).
- 1pc - hook puller 16mm (dia.).
- 1pc - pneumatic vacuum sliding hammer.

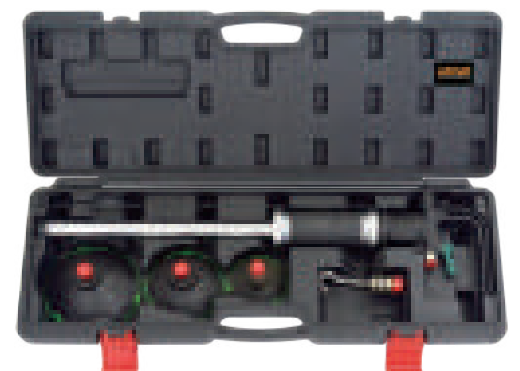

ST-22087

4PCS - PNEUMATIC DENT PULLER SET

- sliding hammer to ease dent without damaging to the paint surface.
- get the power and versatility of a slide hammer without marring the finish by welding or drilling body panels.
- pneumatic control creates a super-strong vacuum making it easy to pull most dents out of panels.
- instantly removes most dents without damaging paint.
- requires air compressor - no drilling, welding or sanding required.
- 3pc - suction pad 60, 120 and 150mm (dia.).
- 1pc - pneumatic vacuum sliding hammer.



ST-24012

3PCS - SLIDING HAMMER WITH LOCKING PLIER SET

- the locking puller can simply pull out any item you want to remove.
- 1.0kg hammer sliding in the end will create a strong pulling force.
- in addition, the bolt can be removed quickly in the joint.
- separating the slide hammer and pliers, used as a rotating ring with locking pliers and it's possible to work in narrow place.
- applications:
pull out the rusty bolts, pull out the staples, pull out the nail, steering wheel, cotter pin, dent puller and fixing pins.
- 1pc - sliding hammer: 1.0 kg.
- 1pc - slider bar: stroke 290 mmL.
- 1pc - locking plier: 250 mmL.

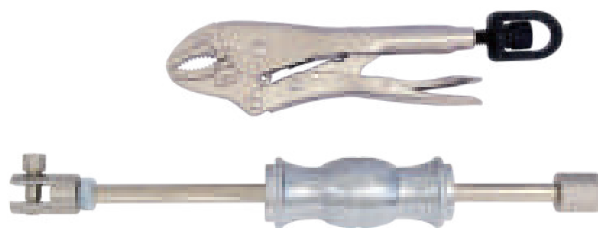

ST-22013

6PCS - AXIAL LOCKING GRIP PLIER SET

- one of a comprehensive range of premier hand tools, suitable for daily professional use.
- manufactured with rounded contours for smooth, secure handling.
- grips feature linear jaw action which applies pressure perpendicular to the workpiece for secure clamping.
- compact size with push-button jaw release is ideal for working in confined spaces.
- quick release action allows one-handed operation.
- suitable for a wide variety of applications including welding, gluing and riveting.



ST-22013A

W-TYPE AXIAL LOCKING GRIP PLIER

- W-type provides for spot welding continued and aligned without tool removal.
- for use on door openings, side panels, jap joints & folded sheet metals.
- auto-body, welding, garage repair work.
- nickel plated finish and electro deposited-coating.
- material: alloy steel and carbon steel.
- jaw-adjustment: 0 ~ 10mm. ● tool length: 200mm.



ST-22013B

JJ-TYPE AXIAL LOCKING GRIP PLIER

- JJ-type clamps two flanged laps, "Z-shaped" profiles or adjacent point.
- plug welding between the jaws.
- for use on center rear-end parts, side panels and folded sheet metals.
- auto-body, welding, garage repair work.
- nickel plated finish and electro deposited-coating.
- material: alloy steel and carbon steel.
- jaw-adjustment: 0 ~ 6.5mm. ● tool length: 230mm.

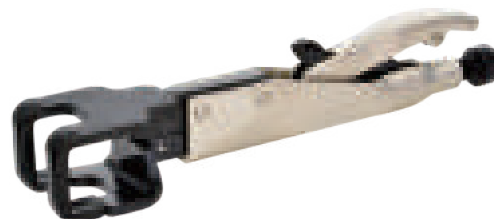

ST-22013C

LL-TYPE AXIAL LOCKING GRIP PLIER

- LL-type "U-shapped" profiles or adjacent points.
- enables to work in tight spots even through holes.
- plug welding between the jaws.
- for use on door seals, wheel arches, side panels & folded sheet metals.
- auto-body, welding, garage repair work.
- nickel plated finish and electro deposited-coating.
- material: alloy steel and carbon steel.
- jaw-adjustment: 0 ~ 7.0mm. ● tool length: 213mm.



ST-22013D

J-TYPE AXIAL LOCKING GRIP PLIER

- J-type clamps "U-shapped" profiles or adjacent points.
- enables to work in tight spots even through holes.
- for use on center rear-end parts, rear side panels and folded sheet metals.
- auto-body, welding, garage repair work.
- nickel plated finish and electro deposited-coating.
- material: alloy steel and carbon steel.
- jaw-adjustment: 0 ~ 10mm. ● tool length: 210mm.

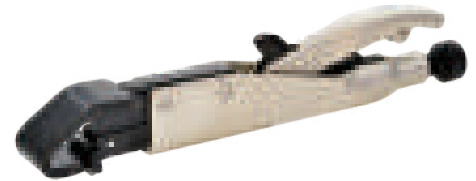

ST-22013E

L-TYPE AXIAL LOCKING GRIP PLIER

- L-type clamps two lap joints.
- especially suitable for work in narrow areas.
- for use on door openings, lower center rear-end parts, wheel arches and problem areas.
- auto-body, welding, garage repair work.
- nickel plated finish and electro deposited-coating.
- material: alloy steel and carbon steel.
- jaw-adjustment: 0 ~ 14.5mm. ● tool length: 195mm.



ST-22013F

T-TYPE AXIAL LOCKING GRIP PLIER

- T-type clamps two sheet metal pieces of equal thickness at 90 degree.
- enable easily work by one operator efficiently.
- auto-body, welding, garage repair work.
- nickel plated finish and electro deposited-coating.
- material: alloy steel and carbon steel.
- jaw-adjustment: 0 ~ 8.0mm. ● tool length: 194mm.



CURVE JAW LOCKING PLIER

ST-28001A overall length: 149 mm. jaw adjustment: 0 ~ 25 mm.

ST-28001B overall length: 185 mm. jaw adjustment: 0 ~ 38 mm.

ST-28001C overall length: 225 mm. jaw adjustment: 0 ~ 48 mm.

- these locking pliers have nickel-plated finish that resists rust & corrosion.
- they have versatile curved jaw with angled tooth pattern for better grip also features integral wire cutter.



LONG-NOSE LOCKING PLIER

ST-28004A overall length: 170 mm. jaw adjustment: 0 ~ 42 mm.

ST-28004B overall length: 215 mm. jaw adjustment: 0 ~ 43 mm.

- these locking pliers have nickel-plated finish that resists rust & corrosion.
- they have versatile curved jaw with angled tooth pattern for better grip also features integral wire cutter.



ST-28006

PINCH-OFF LOCKING PLIER

- the hose pinch plier feature rounded off jaw edges to prevent internal damage.
- suitable for brake, coolant, fuel and vacuum hoses.
- overall length: 285 mm.
- jaw adjustment: 0 ~ 100 mm.



C-CLAMP LOCKING PLIER

ST-28007A	overall length: 170 mm.	jaw adjustment: 0 ~ 40 mm.
ST-28007B	overall length: 280 mm.	jaw adjustment: 0 ~ 90 mm.
ST-28007C	overall length: 445 mm.	jaw adjustment: 0 ~ 160 mm.
ST-28007D	overall length: 605 mm.	jaw adjustment: 0 ~ 230 mm.

- forward release lever allows for smooth and ease unlocking.

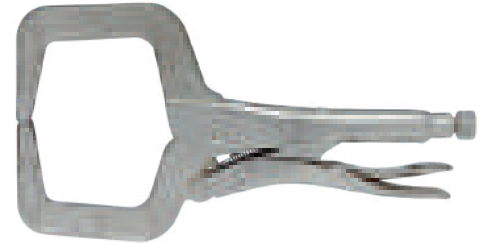

SHEET METAL LOCKING PLIER

ST-28009A	overall length: 200 mm.	jaw adjustment: 0 ~ 30 mm.
ST-28009B	overall length: 250 mm.	jaw adjustment: 0 ~ 50 mm.

- use to crimp, bend, form, or stretch work pieces, quick release trigger rapidly unlocks tool.



WELDING CLAMP LOCKING PLIER

ST-28010A	overall length: 225 mm.	jaw adjustment: 0 ~ 60 mm.
ST-28010B	overall length: 265 mm.	jaw adjustment: 0 ~ 85 mm.

- U-shaped jaws provide enhanced visibility and more working space.
- for use in welding applications or for holding awkward shapes in place.



ST-28017

PARROT PLIER WITH SAWTEETH

- sawteeth jaw provide a stronger grip.
- the jaw grip on three sides of the fastener guaranteeing a firm grip well hold and easy to remove nuts, bolt, pipe etc.
- jaw gripping: 6~32 mm
- overall length: 215 mmL.



SELF ADJUSTING MULTI-GRIP PLIER

ST-29049A	length: 175 mm.	jaw capacity: 40 mm.
ST-29049B	length: 255 mm.	jaw capacity: 60 mm.

- allow a firm grip on various sized and shaped objects self-locking jaw reduce slippage and fatigue.
- ideal for such as piping, water pump and slip joint, as well as a number of other automotive applications.
- innovative spring loaded design allows the jaw adjustable to any size enabling a quick and one hand operation.
- plier feature straight and V-type jaw for hex, square and round objects.
- deeply serrated, lockable jaw allow for a maximum grip & reduces fatigue.

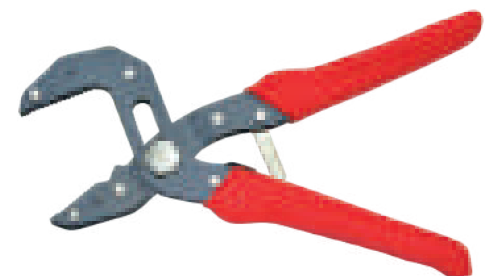

ADJUSTABLE CURVE JAW W/SWIVEL PAD LOCKING PLIER

ST-28013A	jaw gripping: 63 mm.	jaw depth: 42 mm.	tool L.: 225 mm.
ST-28013B	jaw gripping: 80 mm.	jaw depth: 70 mm.	tool L.: 250 mm.
ST-28013C	jaw gripping: 80 mm.	jaw depth: 70 mm.	tool L.: 250 mm.
ST-28013D	jaw gripping: 95 mm.	jaw depth: 90 mm.	tool L.: 270 mm.

- for use in welding applications or for holding awkward shapes in place.
- rack with 4 setting positions for clamping any shape.
- designed with serrated execution.
- suitable for round and flat material.



ST-22006

4PCS - STEEL CHISEL SET

- dismantling stubborn components.
- holding components in required position.
- spreading clamp-fixture, etc.
- 1pc - slim-profile chisel: W25 mm x 230 mmL.
- 1pc - slim-profile chisel: W26 mm x 230 mmL.
- 1pc - wide chisel with guard: W26 mm x 235 mmL.
- 1pc - wide chisel with guard: W57 mm x 250 mmL.

ST-22005

13PCS - BODY PRY BAR AND WEDGE TOOL KIT

- designed to remove and install tyre.
- used for automotive body repair.
- these pry bars are manufactured from special steel and are particularly suitable for dismantling stubborn component, holding component in required position, positioning component and spreading clamp-fixture.
- 5pc - pry bar: 300 - 450 - 570 - 740 - 900 mmL.
- 2pc - S type pry bar: 410 - 490 mmL.
- 1pc - L type body wedge: 130 x 263 mmL.
- 5pc - body wedge:

45 mm x 111 mmL.	52 mm x 112 mmL.
71 mm x 111 mmL.	85 mm x 113 mmL.
140 mm x 263 mmL.	

ST-22076

5PCS - ALUMINUM BODY HAMMER AND DOLLY REPAIR SET

- aluminum hammers help to prevent crossing contamination / provide more forgiving strike on aluminum bodied vehicles.
- rubber dollies provide a lighter option when accessing a tight, confined location behind an aluminum panel.
- 1pc - aluminum pein / finishing hammer (vertical-large).
- 1pc - aluminum bumping hammer.
- 1pc - rubber toe dolly.
- 1pc - rubber general purpose dolly.
- 1pc - rubber heel dolly.

ST-22077

9PCS - ALUMINUM BODY HAMMER REPAIR SET

- aluminum hammers prevent crossing contamination on aluminum bodies vehicles.
- aluminum hammers provide more forgiving strike than other hammers, avoiding further damage on aluminum panels.
- 1pc - aluminum round large head hammer.
- 1pc - aluminum pein / finishing hammer (horizontal large).
- 1pc - aluminum pein / finishing hammer (vertical large).
- 1pc - aluminum pein / finishing hammer (horizontal medium).
- 1pc - aluminum pein / finishing hammer (vertical medium).
- 1pc - aluminum pein / finishing hammer (horizontal small rubber cap).
- 1pc - aluminum pein / finishing hammer (vertical small rubber cap).
- 1pc - aluminum bumping hammer.
- 1pc - aluminum pick / finishing hammer.

ST-22081

3PCS - GAP GAUGE TOOL SET

- for correct body / interior alignment.
- original dimension can be determined in advance.
- gap to be set from 1mm ~ 10mm.
- measuring capacity from 0.5mm ~ 11.5mm.

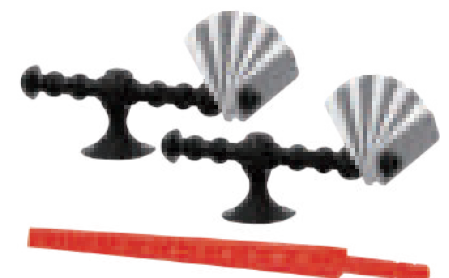
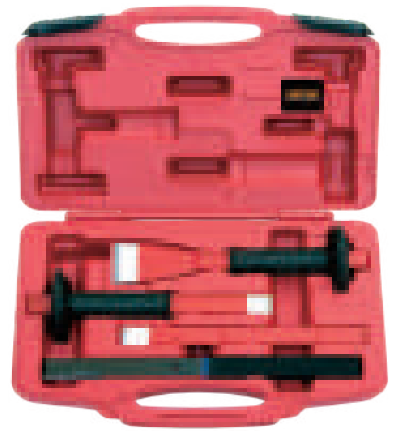

ST-22080

STEPPED LEVER WEDGE

- designed to assist alignment of panels and glass.
- steps in the tip to help gauge consistent spacing when resetting panels or glass.
- manufactured from POM material which is rigid and non-marking.
- won't damage painted or glass surfaces.



ST-28014

PUNCH TOOL

- this hand punch tool can crimp panel edges for excellent weld repair.
- with this tool in place, you & your crew will be able to achieve the best looking & perfectly fitting replacement panels, even if they are big & flat, without any warping.
- punch hole 5 mm (dia.) x deep throat 40 mm for plug welds.

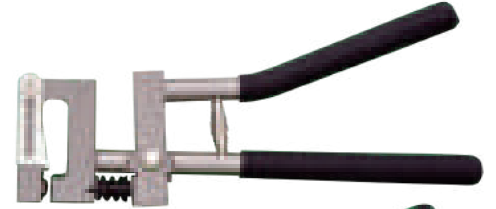

ST-28015

FLANGE TOOL

- this flange tool can crimp panel at seam for superior weld repair.
- with this tool in place, you and your crew will be able to achieve the best looking and perfectly fitting replacement panels, even if they are big and flat, without any warping.

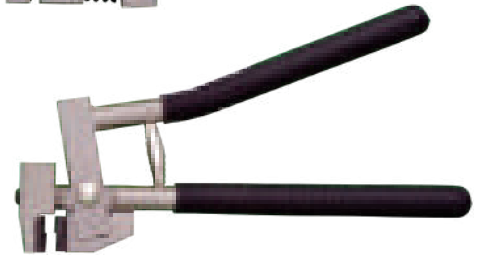

ST-28016

3-EDGE DURABLE PAINT SCRAPER

- with this paint scraper can remove paint, varnish, rust and even glue.
- it is suitable for all surfaces, like wood, metal and concrete.
- the scraper comes with 3-edge carbide blade, which is very durable, if it is dull, it can be reversed.
- the carbide blades hold 50 times longer than conventional steel blades and does not have to be sharpened.



ST-22067

CONTOUR GAUGE

- it helps to make sure the left and right sides match when repairing wheel arch profiles, bodywork contours, or forming your own panels.
- many nylon blades assure faithful reproduction of even the finest details.
- there are two magnets attached to the gauge, and it makes the working more easily on a magnetic reference plane.
- overall length: 125 mmL.



ST-22068

CONTOUR GAUGE

- it helps to make sure the left and right sides match when repairing wheel arch profiles, bodywork contours, or forming your own panels.
- many nylon blades assure faithful reproduction of even the finest details.
- there are two magnets attached to the gauge, and it makes the working more easily on a magnetic reference plane.
- overall length: 250 mmL.

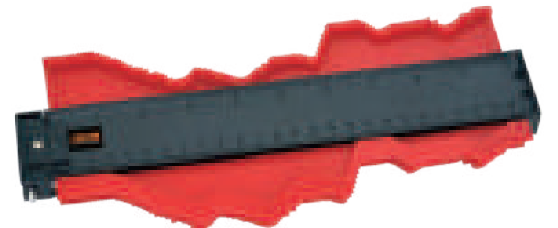

ST-22055

TRIM CLIP REMOVER PLIER

- this drop forged tapered "V" opening tool removes upholstery clip from car door, panel and bumper.
- the double tapered tips slide under the clip and grip to prevent damaging.
- the tips is 45°, providing more leverage for easier clip removal in tight spots.



ST-22058

SPECIAL BUMPING MALLET

- mallet with special rubber filler that is elastic in nature, but hard when in use.
- for pushing in and fixing vehicle door weatherstrip, fender flare, & bumper.
- avoid scratching and damaging bumper, panel, and car body in general.
- rubber body size: hexagon 75 mm x 60 mm (h.).



ST-22052

12PCS - BUMPER DRILL SET

- easy and professional punching of holes, according to the requirement for most of automobile manufacture.
- with the right cutter a custom-fit hole is punched into the bumper.
- 18.2 mm (dia.) punch & mandrel: for usual models from BMW, VW.
- 24.0 mm (dia.) punch & mandrel: for usual models from Opel.
- 26.0 mm (dia.) punch & mandrel: for usual models from VW.
- 32.0 mm (dia.) punch & mandrel: for usual models from BMW.



ST-22053

HOT STAPLER PLASTIC REPAIR SYSTEM SET

- new design hot plastic stapler lightweight.
- handheld machine enables metal staple to be pressed into plastic quickly and simple process.
- lugs on lighting housing and splits in plastic parts can be stapled together.
- power input: 100 ~ 240 Volt - 50 / 60 Hz.
- power output: max. to 20 watt.
- vibration frequency: 8MHz.
- set come with: 100pc - V-type nails 0.6 mm (dia.).
100pc - U-type nails 0.8 mm (dia.).
100pc - U-type nails 0.6 mm (dia.).



ST-22088

HOT STAPLER PLASTIC REPAIR SYSTEM SET

- new design hot plastic stapler lightweight.
- handheld machine enables metal staple to be pressed into plastic quickly and simple process.
- lugs on lighting housing and splits in plastic parts can be stapled together.
- power input: USB charging cord.
- power output: max. to 30 watt.
- 2pc - stainless steel mesh for reinforcement 50 x 100mm.
- 50pc - W-type nails 0.6 mm (dia.).
50pc - W-type nails 0.8 mm (dia.).
- 10pc - welding materials (PP). 5pc - welding materials (PE).
5pc - welding materials (PS). 5pc - welding materials (ABS).



ST-22083

32PCS - GAS-POWERED SOLDERING IRON PLASTIC REPAIR KIT

- great for welding & repairing plastic parts or components, vehicle bumpers, broken headlight fixings, cracks, fractures and deep scratches.
- 1pc - butane-powered soldering iron (plastic welding tip 9mm) with housing.
- 3pc - stainless steel mesh for reinforcement 100 x 60mm.
- 1pc - plastic welding tip 12mm. 1pc - iron rod.
1pc - copper brush. 1pc - screwdriver SL3.0 x 50mmL.
- 6pc - welding materials (PP). 6pc - welding materials (PE).
6pc - welding materials (PC). 6pc - welding materials (ABS).



ST-22049

6PCS - VELCRO SANDING BLOCK KIT

- a very useful 6 pcs sanding block kit with both concave and convex adaptors.
- 2pc - curve block: 85*150mmL.
1pc - half-moon block: 105x150mmL.
1pc - gap block: 190 x 130 mmL.
1pc - half-moon block: 120x150mmL.
1pc - flat block: 80 x 150 mmL.

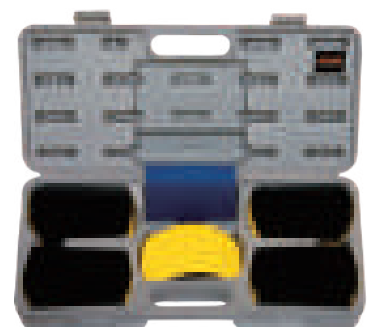

ST-23030

3PCS - STRAIGHT PINCH-OFF PLIER SET

- unique designed jaws prevent internal hose lining from destruction.
- lightweight for handle and non-conductive safety.
- "A" for up to 10 mm line diameter.
- "B" for up to 15 mm line diameter.
- "C" for up to 24 mm line diameter.

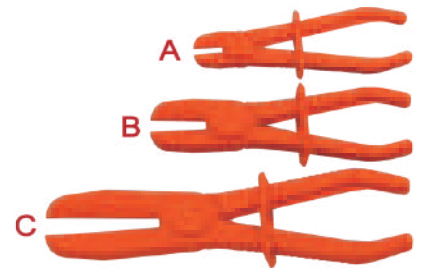

STRAIGHT PINCH-OFF PLIER

ST-23030A for up to 10 mm line diameter.

ST-23030B for up to 15 mm line diameter.

ST-23030C for up to 24 mm line diameter.

- unique designed jaws prevent internal hose lining from destruction.

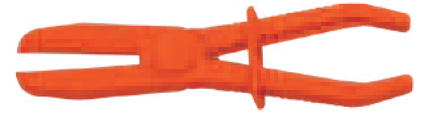

ST-23061

3PCS - ANGLE PINCH-OFF PLIER SET

- unique designed jaws prevent internal hose lining from destruction.
- lightweight for handle and non-conductive safety.
- "A" for up to 10 mm line diameter.
- "B" for up to 15 mm line diameter.
- "C" for up to 24 mm line diameter.

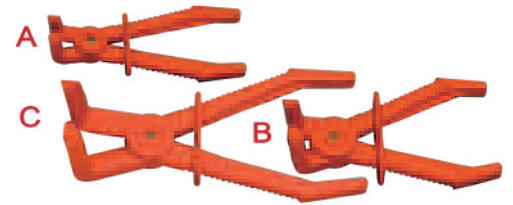

ANGLE PINCH-OFF PLIER

ST-23061A for up to 10 mm line diameter.

ST-23061B for up to 15 mm line diameter.

ST-23061C for up to 24 mm line diameter.

- unique designed jaws prevent internal hose lining from destruction.
- lightweight for handle and non-conductive safety.

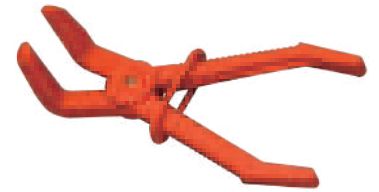

ST-23060

HOSE CLAMP PLIER

- swivel jaw are slotted for positive holding of large or small clamp at any angle.
- ratchet action holds jaw closed in 5 different positions.
- suitable for all automotive and appliance spring wire hose clamp.



ST-23063

FLEXIBLE HOSE CLAMP PLIER

- hose clamp with flexible 600 mmL. wire.
- convenient for working hidden area and long distance.
- suitable for removal of hose clamp on fuel, oil and water hose.



ST-23028

9PCS - HOSE CLAMP PLIER KIT

- including different types of hose clamp plier.
- comprehensive set features h. d. construction w/ratchet lock mechanism on most pliers.
- soft-grip handle for comfortable.
- suitable for removal of hose clamp on fuel, oil and water hose.
- 1pc - swivel jaw (-) hose clamp plier.
- 1pc - swivel jaw (+) hose clamp plier.
- 1pc - hose remove plier.
- 1pc - spare part for flexible hose clamp.
- 1pc - 2 way screw-driver.
- 1pc - angled flat band hose clamp plier.
- 1pc - hose clamp plier.
- 1pc - swivel jaw hose clamp plier.
- 1pc - flat band hose clamp plier.



ST-23083

STRAIGHT HOSE CLAMP PLIER

- comprehensive set features h. d. construction w/ratchet lock mechanism on most pliers.
- finger tip "position lock" to keep hose clamp spread open.
- suitable for removal of hose clamp on fuel, oil and water hose.
- jaw opening up to 65 mm.
- overall length 280 mmL.



ST-23084

EXTRA-LONG STRAIGHT HOSE CLAMP PLIER

- comprehensive set features h. d. construction w/ratchet lock mechanism on most pliers.
- finger tip "position lock" to keep hose clamp spread open.
- suitable for removal of hose clamp on fuel, oil and water hose.
- jaw opening up to 50 mm.
- overall length 430 mmL.



ST-23085

35° BENT TYPE HOSE CLAMP PLIER

- comprehensive set features h. d. construction w/ratchet lock mechanism on most pliers.
- finger tip "position lock" to keep hose clamp spread open.
- suitable for removal of hose clamp on fuel, oil and water hose.
- jaw opening up to 65 mm.
- overall length 265 mmL.



ST-23086

35° EXTRA-LONG BENT TYPE HOSE CLAMP PLIER

- comprehensive set features h. d. construction w/ratchet lock mechanism on most pliers.
- finger tip "position lock" to keep hose clamp spread open.
- suitable for removal of hose clamp on fuel, oil and water hose.
- jaw opening up to 50 mm.
- overall length 420 mmL.



ST-23058

RADIATOR HOSE REMOVER SHARK-TOOTH PLIER

- this heavy-duty removal plier is ideal for the removal of radiator hoses and clamps.
- no more struggling as this get the job done quickly and efficiently.
- thickness 5.0 mm and 290 mmL.

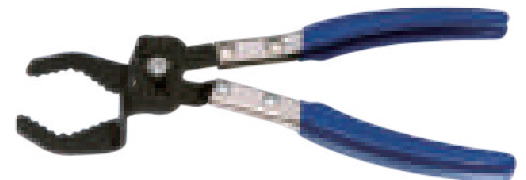

ST-24629

ADJUSTABLE OPENING AND HOLDING FLARING TOOL SET

- adjust from same point for every size.
- strength saving operation.
- inch and metric integrated.
- specification for 4 mm ~ 16 mm. (3/16" ~ 5/8") o.d.



ST-23079

COOLING SYSTEM FLUSHER

- ideal for fast and efficient rinsing of the cooling system.
- restores optimum operation of the cooling system.
- can be used without solvent or aggressive chemical.
- work in conjunction w/compressed air and water, increasing the water pressure.
- the cooling system flush gun is equipped with a standard 1/2" water connection.
- universal rubber nozzle with various diameters 19/29/32/36.5 & 40mm.
- for all common coolant hoses.



ST-24635

7PCS - TUBE BENDING TOOL KIT

- compact and light weight, and powerful.
- bending pipes up to 12mm in diameter with minimum effort.
- quick and easy to use, one handed manual operation.
- suitable for bending pipes over 180°.
- specification for 5, 6, 8, 10, 12mm outside diameter.



ST-25050

9PCS - FUEL LINE DISCONNECT TOOL SET

- designed for A/C line, fuel line, and transmission cooler line.
- contains 3/8", 1/2", 5/8" and 3/4" spring lock disconnect tool for A/C line on 1981 thru 2003 Ford vehicle and truck.
- 1994 thru 2003 Chrysler and Jeep vehicle. contains the 3/8" and 1/2" fuel line disconnect tool for Ford vehicle.
- contains the 5/16" & 3/8" fuel line disconnect tools for GM & Chrysler vehicle.
- contains the transmission oil cooler line disconnect tool used on many GM and Ford vehicle.



ST-24568

7PCS - A/C FUEL LINE DISCONNECT TOOL SET

- this seven pieces fuel line and air conditioning disconnect set help to disconnect the fitting of fuel line & air conditioning quickly and easily, even if they are in hard-to-reach parts of your car.
- size include:
6.4 mm, 7.9 mm, 9.5 mm, 12.7 mm, 15.9 mm, 19 mm and 22.2 mm.
- applicable:
Chrysler, Ford, GM, Daihatsu, Honda, Mercedes, Mitsubishi, Nissan, Saab, Vauxhall, Scania, VW, Volvo, ect.



ST-24646

UNIVERSAL RADIATOR DRAIN PLUG SOCKET

- double slotted end (3mm x 5mm) will fit most radiator drain plug that have thump wings.
- cooling: remove / install radiator drain plugs that have thump wings.
- reach into confined areas.
- operation with 17mm spanner or 3/8" dr. ratchet handle.



ST-23010

8PCS - FUEL / TRANSMISSION AND A/C LINE DISCONNECT KIT

- designed for A/C line, fuel line and transmission cooler line.
- all the disconnect tool need to work with spring locking coupling, fuel line, and transmission cooler line.
- two ends disconnect tool: 5/16" ~ 3/8".
- long disconnect tool: 1/2".
- round disconnect tool: 1/2".
- two point disconnect tool and rubber cap x 4.
- 1/4" (black). 5/16" (red). 3/8" (yellow). 1/2" (blue)



ST-23011

13PCS - DELUXE A/C CLUTCH HUB PULLER INSTALLER KIT

- kit contains a complete offering of A/C compressor clutch.
- hub puller and installer for GM, Ford, Chrysler and so on.
- includes a compressor identification chart.
- 1pc - holding pad.
- 3pc - holding screw.
- 9pc - pull screw set.



ST-23054

22PCS - FUEL AND A/C LINE DISCONNECT KIT

- designed for A/C line, fuel line and transmission cooler line.
- all the disconnect tool need to work with spring locking coupling, fuel line, and transmission cooler line.
- 6pc - fuel & air conditioning line disconnect:
 - 5/16" - 3/8" - 1/2" - 5/8" - 3/4" - 7/8".
- 4pc - Ford A/C spring lock coupling:
 - 3/8"(red) - 1/2"(blue) - 5/8"(black) - 3/4"(green).
- 1pc - Ford oil cooler line disconnect tool.
- 1pc - Ford/GM quick disconnect tool.
- 7pc - A/C, fuel line disconnect set. 1pc - fuel line disconnect tool.
- 1pc - rubber band. 1pc - Ford fuel line coupling tool.



ST-23007

10PCS - FAN CLUTCH SERVICE KIT

- removal of lock nuts on viscous fan on MB, BMW, Ford and any other vehicles.
- special open-end spanner to remove and replace the radiator fan hub.
- the technician can hold the water pump pulley in place while loosening radiator fan then remove the visco-coupling on the cooling fan.
- 3 in 1 design allows serving of three repair, which is required a special tool due to their separate areas of confined locations.



ST-23004

11PCS - UNIVERSAL PULLEY HOLDER AND FAN CLUTCH KIT

- this set is designed to remove and install fan clutch and hold the camshaft pulley.
- available for most of cars with different tap size and adjustable pin width.
- adjustable different width from 40 mm to 220 mm.
- available size: 6 ~ 10, 8 ~ 11, 10 ~ 12, 11 ~ 16 mm (dia.).



ST-23005

15PCS - UNIVERSAL PULLEY HOLDER AND FAN CLUTCH KIT

- this set is designed to remove and install fan clutch and hold the camshaft pulley.
- available for most of cars with different tap size and adjustable pin width.
- adjustable different width from 40 mm to 320 mm.
- available size: 6 ~ 10, 8 ~ 11, 10 ~ 12, 11 ~ 16 mm (dia.).

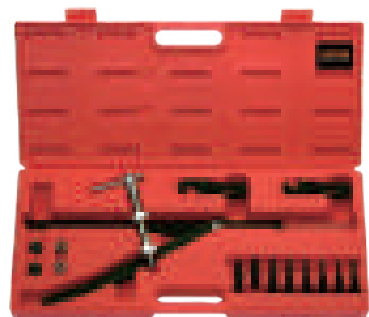

ST-23038

4PCS - COOLANT FILLING TOOL SET

- quick and easy way to refill coolant during cooling system bleeding process.
- quick, efficient and no mess.
- black- Japanese vehicles, American vehicles.
- red - Mitsubishi, Ford, Nissan, Mazda.
- blue - Honda, Toyota, Suzuki.



ST-23076

13PCS - COOLANT REFILLING FUNNEL WITH EXTENSION PIPES SET

- for anti-spill coolant refilling and air bleeding.
- includes 4 extension pipes for confined space or tricky angles.
- transparent lower chamber displays the amount of air bubble remaining in the radiator.
- includes adapters with nylon covers to reduce heat transfer resulted from air bleeding.
- special design of connector to adapters provides anti-spill feature.
- funnel capacity: 1,500 ml. large capacity suitable for working on truck and heavy-duty vehicles.



ST-23092

8PCS - COOLANT REFILLING FUNNEL SET

- for anti-spill coolant refilling and air bleeding.
- transparent lower chamber displays the amount of air bubbles remaining in the radiator.
- included 3 steel connector caps mainly for american and japanese vehicles, & one universal adaptor with 3 rubber rings for european cars.
- with enlarged capacity is suitable for SUV, light trucks and h. d. vehicles.
- special connector design to adaptors provides an anti-spill feature.
- capacity: 750 ml.



ST-23046

7PCS - RADIATOR PRESSURE TESTER KIT

- remove the original radiator cap while the engine is cold.
- choose a proper radiator cap and install it on to radiator opening.
- connect the pump to the test cap through the coupling at the hose end.
- manual pump with quick joint and release valve.
- connector R123 / R124 (black color).
- connector R123 / R125 (blue color).
- R124 - suitable for Peugeot, Subaru, Chrysler, Acura, GM (Nova, Spectrum & Sprint), Mitsubishi, Nissan, Mazda, Toyota, Infiniti, Geo, Suzuki, Isuzu, Ford.
- R123 - suitable for Mercedes Benz, GM (Buick) and Jeep.
- R125 - suitable for Honda, Toyota, Suzuki, Mitsubishi, Chrysler & Acura.



ST-23101

5PCS - UNIVERSAL RADIATOR PRESSURE TESTER KIT

- the adaptor's expandable rubber body allow user to connect to most automotive cooling systems without the need for additional costly adaptors.
 - user can perform pressure testing and cooling system diagnostics simultaneously.
 - 0~35 psi, colour-coded gauge, and pressure release valve.
- adaptor size:
- | | |
|--------------|------------|
| 16.5 ~ 37mm. | 38 ~ 50mm. |
| 28 ~ 42mm. | 46 ~ 60mm. |



ST-23102

10PCS - UNIVERSAL RADIATOR CAP PRESSURE TESTER KIT

- pressure tester to check the gasket of radiator cap.
 - instantly detect leakage of cooling system.
 - multi adaptor included which apply for most vehicles in the market.
 - hand pump with colour-coded gauge.
 - 0~35 psi, colour-coded gauge, and pressure release valve.
- no. 1 (blue): Toyota, Honda.
 - no. 2 (orange): Mitsubishi, Ford, Nissan, Mazda.
 - no. 3 (black): Nippon Hino.
 - no. 4 (orange) Renault, Audi, VW.
 - no. 5 (red): Volvo, Citroen, Renault, Fiat, Peugeot.
 - no. 6 (yellow): Opel, VW, Ford.
 - no. 8 (black): BMW.
 - no. 7 (green): Volvo, Renault.
 - no. 9 (black): Mercedes.



ST-23015

14PCS - UNIVERSAL RADIATOR PRESSURE TESTER KIT

- remove the original radiator cap while the engine is cold.
- choose a proper radiator cap and install it on to radiator opening.
- connect the pump to the test cap through the coupling at the hose end.
- pump until pressure is approximately 10~15 psi. if the gauge pointer does not move for approximately 1 min., the whole circuit is perfectly efficient; if it goes down, the circuit leaks, where water is discharged; if the gauge goes down & no fluid discharge can be located, check whether the engine head gasket is worn.
- finally, release pressure through the button next to the coupling, and put away the device, after removing any fluid or dirt.



ST-23078

24PCS - UNIVERSAL RADIATOR PRESSURE TESTER KIT

- set for testing leaks in automotive cooling system.
- adaptors and pump are made of light nylon 66.
- provided with blue and black connectors are testing pressure caps.
- includes a thermometer for safety reason.
- Alfa Romeo / Audi / BMW / Cadillac / Chevrolet / Chrysler / Citroën / Dacia / Daewoo / Daihatsu / Dodge / Fiat / Ford / Holden / Honda / Hyundai / Isuzu / Jaguar / Jeep / Kia / Lancia / Land Rover / Lexus / Maserati / Mazda / Mercedes Benz / Mini / Mitsubishi / Nissan / Opel / Peugeot / Pontiac / Porsche / Proton / Renault / Saab / Saturn / Scion / Seat / Skoda / Subaru / Suzuki / Toyota / Vauxhall / Volvo / VW.



ST-23050

27PCS - PRESSURE AND VACUUM TYPE COOLING TESTER KIT

- remove the original radiator cap while the engine is cold.
- choose a proper radiator cap and install it on to radiator opening.
- work the hand pump till the pressure up to 10~15 psi.
- check the gauge reading, if the reading drops automatically, the leakage might occur in radiator.
- raise the vehicle bonnet and hand the hook in available position.
- connect the universal radiator rubber adaptor provided or suitable radiator cap on radiator.
- connect air line, press button "ON" to allow the air gone. turn switch 50~60cmHG, then press button "OFF".
- Alfa Romeo: 146 / 156 / 166 / GTV / Spider.
Audi: A2 / A4 / A5.



ST-23117

31PCS - PRESSURE AND VACUUM TYPE COOLING TESTER KIT - electric vehicles

- remove the original radiator cap while the engine is cold.
- choose a proper radiator cap and install it on to radiator opening.
- work the hand pump till the pressure up to 10~15 psi.
- check the gauge reading, if the reading drops automatically, the leakage might occur in radiator.
- raise the vehicle bonnet and hand the hook in available position.
- connect the universal radiator rubber adaptor provided or suitable radiator cap on radiator.
- connect air line, press button "ON" to allow the air gone. turn switch 50~60cmHG, then press button "OFF".
- Audi e-Tron, BMW i3, BMW i8, Chevrolet Bolt EV, Hyundai Kona Electric, Hyundai Ioniq Electric, Kia Niro EV, Mitsubishi Outlander PHEV, Nissan e-NV200, Nissan Leaf, Renault Zoe, Toyota Prius PHEV, Volvo XC40 / XC60 Hybrid, VW e-Golf.



ST-23075

33PCS - PRESSURE AND VACUUM TYPE COOLING TESTER KIT

- carefully undo & remove the radiator cap use a damp cloth or gloves and arm protection if the radiator cap is known to be hot.
- choose a proper radiator cap and install it on to radiator opening.
- attach the "push-fit" connector onto the male tailpiece of the adaptor fitted to the radiator.
- once the testing is completed, release the air pressure pressing release valve. disconnect the quick coupler & adaptor assembly.
- application:
Mercedes Benz, Honda, Toyota, VW, Audi A4 A5 A6, Mitsubishi, Ford, Nissan, Mazda, Opel, BMW, Jeep, Volvo, Citrön, GM, GM truck, Suzuki, Ford fiesta, Mazda 3, Ford Mondeo, Toyota Rav4.



ST-23093

6PCS - COOLING SYSTEM VACUUM PURGE AND REFILL KIT

- quick coupler attachments, no more bleeding and saves clean up time.
- easy to connect with air pump & creates a vacuum to the filler hose .
- opening the valve & letting the pre-mixed coolant flow into the system.
- uses shop air to evacuate and leak test an auto cooling system.
- use to refill coolant in minutes, reduces the refill time of cooling system and prevents the air flow into the system.
- 1pc - gauge.
- 1pc - vacuum gauge.
- 1pc - coolant hose.
- 3pc - adaptor.



ST-23094

4PCS - VACUUM-TYPE COOLING SYSTEM FILLER KIT

- this is a special tool kit for cars, it's used for car antifreeze replacement and filling.
- significantly reduces coolant replacement time without entering the air.
- copper-plated connectors, rust-proof & beautiful, durable & wear-resistant.
- the pressure measurement is accurate, and the water tank leakage can be found in time.
- simple operation and wide application.
- can be used in 4S shops, auto repair shops, and personal DIY.
- 1pc - vacuum purge refill tool.
- 1pc - universal radiator adaptor.
- 1pc - coolant hose.
- 1pc - transparent hose.



ST-23081

9PCS - HGV COOLING SYSTEM PRESSURE TESTER KIT

- set for testing leak in heavy duty vehicles (HGV) cooling system.
- include 7 adaptors for major HGV brand.
- MB: sprinter-2006/vito-2006/actros-1997/atego-1998/axor-2001/eco-8401.
- Deutz engine: 1015. volvo: fh12-1993 / fl-2000 / fm-1998.
- Man: l-2000 1993-2000 / tga-2000 / e2000-2000 / f2000 1995-2003 / f90 1987-1996 / tga/l/m/s 2005.
- Daf: lf55 2001 / xf95 2002-2006 / xf105 2005.
- Iveco: eurocargo 1991/eurostar 1993-2001/euro tech 1993-2001/euro trakker 1993-2001/euro trakker cursor 2002/euro trakker cursor 13 2001/euro truck stralis cursor 2002.
- Renault: kerax 1999 / magnum 1990-2003 / midlum 2000 / premium 1997.
- Scania: 4 series 1995-2004, 93, 94 1996-2004, 113, 114 1996-2004, 124 1996-2004, 144 1996-2002, 164 1999-2004.



ST-24665

IGNITION COIL PULLER

- suitable for removal of spark plug boot on deep-seated engine application.
- used for removing pencil-type ignition coil on 1.0L / 1.0L TSI / TFSI-1.2L TSI - 1.4L TSI / TFSI - 2.0L GTI engines.
- suitable:
 - VW - Up 2011~, Polo 2012~, Golf 2013~, Beetle 20014~, Caddy 2015~, Passat 2014~, Tiguan 2015~, Touran 2015~, Sharan 2015~.
 - Audi - A1 2012~, A3 2013~.
 - Sköda - Citigo 2011~, Fabia 2014~, Octavia 2013~.
 - Seat - Mii 2011~, Ibiza 2013~, Leon 2013~



ST-23057

HEAVY DUTY SPARK PLUG BOOT PLIER

- thin and long body is suitable for removing hard-to-reach spark plug boot.
- double insulated tip offer complete protection against shock.
- jaw is double dipped to assure complete coverage of all contact area.
- angled nose for easier access to boot.



ST-23064

HEAVY DUTY SPARK PLUG BOOT PLIER

- use to remove the "BERU" type wire and tough to reach spark plug wire on most of automobile.
- wide grip section and special angle make it easy to remove plug wire without separating or damaging connector, wires or shield.
- application include Mercedes Benz and Ferrari.

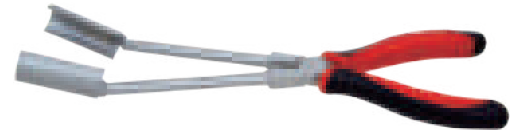

ST-24523

4PCS - IGNITION COIL PULLER KIT

- suitable for removal of spark plug boot on deep-seated engine application.
- A suitable e.g. (VW/Bora/Golf/New Beetle/Passat/Polo/Touran 1.4/16, 6L / Lupo 4-Zyl / FSI / Phaeton and T4.)
- B suitable e.g. (VW/Bora/Golf/Passat/Sharan/Touareg/Passat/Sharan/Touareg/Passat/Sharan/Touareg/Phaeton and T5.)
- C suitable e.g. (VW Golf/Touran/Eos/Passat/Audi A3 2.0 and A6 3.2.)
- D suitable e.g. (VW 8 and 12 cylinder engine.)



ST-23088

5PCS - 1/4" DR. GLOW PLUG JOINT SOCKET SET

- 1/4" dr. and 12 point socket easy to fasten and unfasten glow plug.
- socket can turn 360°, suitable for working in limited space.
- size include 8, 9, 10, 12, 14 mm x 70 mmL.
- application:
 - 8mm - Ford / Iveco / Mercedes / Psa / Renault / Volvo.
 - 9mm - Alfa Romeo / Fiat / Opel / Seat / Volkswagen.
 - 10mm - Audi / Ford / Mercedes / Peugeot / Seat / Volkswagen.
 - 12mm - BMW / Hyundai / Opel / Psa / Toyota Hilux & Land Cruiser.
 - 14mm - universal.



ST-23023

6PCS - 3/8" DR. GLOW PLUG JOINT SOCKET SET

- 3/8" dr. and 12 point socket easy to fasten and unfasten glow plug.
- socket can turn 360°, suitable for working in limited space.
- size include 8, 9, 10, 12, 14, 16 mm x 70 ~ 78 mmL.
- application:
 - 8mm - Ford / Iveco / Mercedes / Psa / Renault / Volvo.
 - 9mm - Alfa Romeo / Fiat / Opel / Seat / Volkswagen.
 - 10mm - Audi / Ford / Mercedes / Peugeot / Seat / Volkswagen.
 - 12mm - BMW / Hyundai / Opel / Psa / Toyota Hilux & Land Cruiser.
 - 14mm - universal.
 - 16mm - universal.



ST-23098

18PCS - GLOW PLUG SOCKET SET

- for disassembly and assembly of common type glow plugs & special PSG glow plugs with pressure sensor, OE number GM 55564163 / 55577419, Opel 1826354 / 1214061, VAG 03L905061D.
- 3pc - 3/8" dr. glow plug socket with universal joint: 8, 9, 10mm x 72mmL.
- 3pc - 1/4" dr. glow plug socket with universal joint: 8, 9, 10mm x 60mmL.
- 3pc - slotted glow plug socket: 8, 9, 10mm.
- 5pc - protecting caps for protecting the connector against pollution and electrostatic charging.
- 1pc - socket, fitting depth 8mm x 50mmL.
- 1pc - glow plug socket with snap ring for PSG, 12mm x 50mmL.
- 1pc - 1/4" dr. extension bar x 100mmL.
- 1pc - 1/4" dr. universal.



ST-23107

11PCS - SWIVEL SPARK AND GLOW PLUG SOCKET SET

- for professional damage-free removal and installation of spark plug and glow plugs as well as "PSG" glow plugs (pressure sensor glow plugs.).
- the socket are provided on the inside with a retaining rubber to prevent the spark / glow plug from falling out unintentionally.
- the special ball joint and the long and slim design of the socket allow even deep-seated glow plug / spark plugs that are difficult to reach to be removed quickly and with easy.
- contents: 1/4" dr. - 8 x mmL, 9 x mmL.
3/8" dr. - 10 x mmL, 12 x mmL. 14 x mmL. 16 x mmL.



ST-23099

16PCS - GLOW PLUG REMOVAL TOOL KIT

- designed for removal of damaged or broken glow plug from cylinder head.
- removes 8mm and 10mm glow plugs.
- set includes all required adaptors for drilling, centring and pulling for the safe removal of glow plug.
- thread repair Audi, VW and Mercedes Benz.



ST-23087

27PCS - GLOW PLUG REMOVAL TOOL KIT

- designed for removal of damaged or broken glow plug from cylinder head.
- set includes all required adaptors, centering and cleaning tool to safely remove glow plug without damaging engine.
- suitable for glow plug with a M8 - M9 - M10 thread.
- cleaning brush: 5.3 mm x 100 mmL. x 300 mmL. (overall length)
- cleaning brush: 9.0 mm x 100 mmL. x 300 mmL. (overall length)
- cleaning brush: 10 mm x 100 mmL. x 300 mmL. (overall length)
- 1/2" dr. adaptor (10 mm hex.).



ST-23105

33PCS - GLOW PLUG THREAD REPAIR TOOL SET

- for repairing the glow plug threads in cylinder head.
- suitable for glow plug threads in sizes: M8 x 1.0mm, M10 x 1.0mm, M10 x 1.25mm, M12 x 1.25mm.
- 6pc - thread sleeves: M8 x 1.0mm, M10 x 1.0mm, M10 x 1.25mm, M12 x 1.0mm, M12 x 1.25mm, M14 x 1.25mm.
- 20pc - thread repair coils, each 5pcs: M8 x 1.0mm, M10 x 1.0mm, M10 x 1.25mm, M12 x 1.25mm.
- 2pc - coil drives. 1pc - guide.
- 3pc - centering pieces. 1pc - guide pin.



SPARK PLUG HOLE THREAD CHASER

ST-23034A	hex 21 mm x M18 x 1.5 p.
ST-23034B	hex 22 mm x M14 x 1.25 p.
ST-23034C	hex 22 mm x M18 x 1.5 p.
ST-23034D	hex 22 mm x M12 x 1.25 p.

- those threads designed to start and remove carbon and dirt or straighten damaged threads in spark plug hole.
- use with ratchet handle and deep socket or suitable wrench.

**ST-23106****9PCS - GLOW PLUG BASE CLEANING REAMER SET**

- special tools for cleaning / re-cutting the glow-plug aperture and for cleaning / re-cutting the glow-plug seat within the cylinder head.
- guide holder size: M8 x 1.0, M10 x 1.0, M10 x 1.25, M12 x 1.25.
- reamer size: M8, M10, M12.
- applications:
 - M8 x 1.0 thread.
 - M10 x 1.0 thread.
 - M10 x 1.25 thread.
 - M12 x 1.0 thread.

**ST-23071****MULTI VOLTAGE GLOW PLUG TESTER**

- this glow plug tester is designed to test the condition of diesel engine glow plug status quickly.
- voltage supply by 9V battery.
- auto switch off.
- rubber coating for tester protection.
- tester probe / clip are easy to replace.
- initialization for different testing probe / clip.

**ST-25025****SPARK PULG AND BATTERY BRUSH**

- battery terminal and post cleaner.
- use bottom brush for cleaning battery post.
- unscrew top and use inside brush for cleaning battery.
- come with metal case.

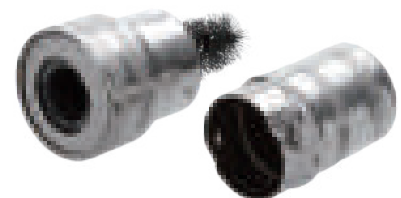
**ST-23036****AIR SPARK PLUG CLEANER**

- this cleaner does abrasive cleaning or air cleaning with just the turn of a switch.
- abrasive blasting removes carbon build-up on spark plug.
- simply hook your compressor hose to the cleaner, insert the plug in the opposite end, set the switch for abrasive or air cleaning, push the start button, and return plug to a like-new condition.
- a flange on each side to fasten the cleaner on workbench.



ST-25037

3PCS - GAS CYLINDER COMPRESSION TESTER SET

- compact tools can solve the trouble of cylinder pressure testing.
- most of the vehicles equipped with fuel injection test cylinder pressure.
- stop engine then disconnect the spark plug and the connecting wire.
- choose a proper adaptor and hose, attach them into cylinder.
- "WARNING" this tester is only suitable for gas cylinder.



ST-23014

8PCS - GAS CYLINDER COMPRESSION TESTER SET

- compact tools can solve the trouble of cylinder pressure testing.
- most of the vehicles equipped with fuel injection test cylinder pressure.
- stop engine then disconnect the spark plug and the connecting wire.
- choose a proper adaptor and hose, attach them into cylinder.
- "WARNING" this tester is only suitable for gas cylinder.



ST-23095

37PCS - DIESEL COMPRESSION TESTER SET

- high quality hydraulic gauge provides accurate reading and prevents damaging.
- on gauge due to high pressure.
- includes 4 injector adaptors and a universal kit.
- provided with 22 glow plug adaptors for nearly all vehicle type on the market.
- glow plug adaptors are helpful when diesel injectors are hard to remove due to carbon deposits.
- includes a 90° adaptor for fitting gauge to injector (or glow plug) adaptor in limited spaces.

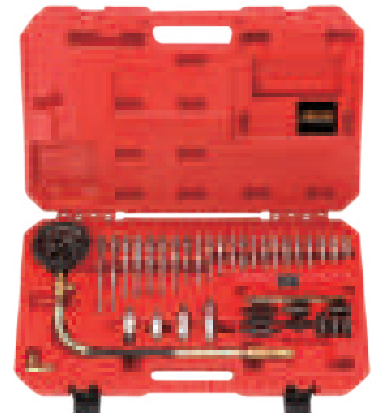

ST-23096

13PCS - DIESEL ENGINE LOW PRESSURE DIAGNOSTIC KIT

- this diagnostic kit is to inspect low pressure or return fuel side of diesel engines.
- two manometers with different scales (-1 - 5 bar and -1 - 15 bar) offer more accurate test results.
- ten fuel line adaptors cover a wide range of diesel engines and car makes.
- translucent tube on adaptors help observing impurities and bubbles in the fuel.
- 2m. long hoses help connections in confined areas in engine compartment.



ST-23068

5PCS - DIESEL INJECTOR SEAT CUTTER SET

- re-face the diesel injector seat in order for the new or reconditioned injector to be fitted correctly.
- clean and re-cutting of injector seat for universal application.
- unique "double lock" design provides highly accurate clean work without damaging engine.



ST-23069

13PCS - DIESEL AND GAS INJECTION REMOVER TOOL SET

- special two jaws design to fix the injector and pull out with slide hammer.
- special design to remove seized diesel injector from VAG TDI engines.
- always allow to cool down the engine before using the tool.
- application:
VW, Audi, FSI & TDII engine code: ALH / AHU / 1Z.



ST-23108

8PCS - VW AND AUDI INJECTOR REMOVER KIT

- this tool kit assists the removal and installation of the high pressure petrol injectors used on direction VAG engines.
- tools are also included for the installation of the injector seals - important to ensure a good seal.
- 1pc - double jaw puller. 1pc - slide hammer
1pc - "U" shaped puller 1pc - tapered tool and sleeve.
3pc - knurled collars. 1pc - injector installer.
- applicable:
VW, Audi with direct injection FSI system.

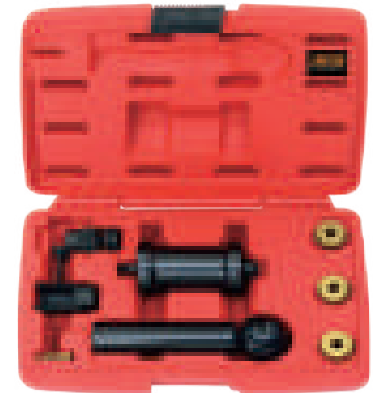

ST-23109

5PCS - VW AND AUDI DIESEL INJECTOR REMOVER KIT

- special design to remove the seized injector form VAG TDI engines.
- always allow to cool down the engine before using the tool.
- with slide hammer these injectors are removes easily without damage.
- applicable:
VW, Audi TDI engine code: ALH / AHU / 1Z.



ST-23110

15PCS - INJECTORS PUMP EXTRACTOR REMOVER KIT

- use "U" sleeve or two jaws hook to fix the injector and then pull out with slide hammer.
- special two jaws design to fix the injector and pull out with slide hammer.
- applicable:
VAG 1.4, 1.6, 1.8, 2.0, 2.7 V6 3.0 V6, 3.2, V6, 3.6, V6, & 4.2 V8 FSI system.



ST-23097

14PCS - OIL PRESSURE TEST KIT

- set for testing engine oil pressure and transmission pressure.
- applicable to both gasoline and diesel engines, also suitable for passenger cars and light trucks.
- gauge reading range from 0~10 bar (0~150 psi).
- provided with an oil filter clamp for piercing through oil filter canister when oil pressure switch is hard to access.
- H-shape oil canister piercer can be offered individually.
- black adaptor:
1/2" x 20UNF, 3/8" x 20UNF, 1/4" x 18UNF, 1/8" x 27UNF, R1/8" DIN
- silver adaptor:
M10 x P1.0, M12 x P1.5, M14 x P1.5, M16 x P1.5, M18 x P1.5.

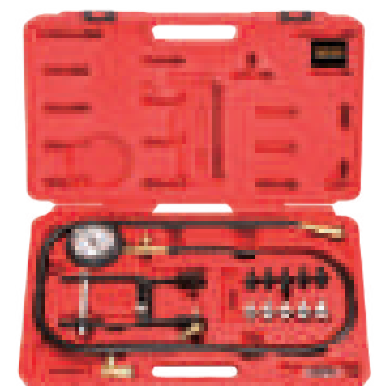

ST-23090

5PCS - VERTICAL-TYPE COMBUSTION GAS LEAK TESTER KIT

- set for testing leaks in head gasket without removing engine cylinder head by testing presence of CO_2 in cooling system.
- includes US-made CO_2 tester fluid.
- tester fluid changes from blue to green or yellow if CO_2 is present in coolant.
- rubber bulb helps draw vapor from radiator into test chambers.
- tester fluid with MSDS and SVHC compliance.

ST-23091

5PCS - HORIZONTAL-TYPE COMBUSTION GAS LEAK TESTER KIT

- set for testing leaks in head gasket without removing engine cylinder head by testing presence of CO_2 in cooling system.
- includes US-made CO_2 tester fluid.
- tester fluid changes from blue to green or yellow if CO_2 is present in coolant.
- provided with a cone-shaped rubber adaptor for fitting most radiator filler necks.
- rubber bulb helps draw vapor from radiator into test chambers.
- tester fluid with MSDS and SVHC compliance.

ST-23077

13PCS - TURBO SYSTEM PRESSURE LEAK TESTER KIT

- pressure test kit for testing turbo system pressure and identifying leaks.
 - charges the turbo system by connecting a low pressure compressed air system through a suitable pressure regulator (not included).
 - 6 pairs of stepped adaptor to fit most common sizes of hose.
 - adaptors are lipped to allow for better grip within the turbo hose end.
 - contents:
- | | | | |
|---------------|---------------|---------------|---------------|
| 51 mm (dia.). | 31 mm (dia.). | 38 mm (dia.). | 46 mm (dia.). |
| 70 mm (dia.). | 55 mm (dia.). | 60 mm (dia.). | 65 mm (dia.). |
| 90 mm (dia.). | 75 mm (dia.). | 80 mm (dia.). | 85 mm (dia.). |

ST-23103

9PCS - TURBO SYSTEM PRESSURE LEAK TESTER KIT

- designed to detect leaks within the turbo system and cooling system hoses.
 - features a pressure gauge with shut off valve, pressure regulator, and pressure release valve.
 - comes with four pairs of adaptor to fit most sizes of hose.
 - adaptor size;
- | | |
|------------|------------|
| 35 ~ 45mm. | 65 ~ 75mm. |
| 50 ~ 60mm. | 80 ~ 90mm. |

ST-23017

45PCS - GASOLINE ENGINE INJECTING PRESSURE TESTER KIT

- serve the most vehicles with fuel injection system.
- allows to diagnose and clean fuel injection system on a wide variety of vehicles.
- all the necessary fittings, hoses, adaptors, disconnect tools, and gauges included.
- disconnect the new-type fuel line with quick connectors can be a touchy operation unless you have the right equipment.
- including the newest fuel line disconnect tools.

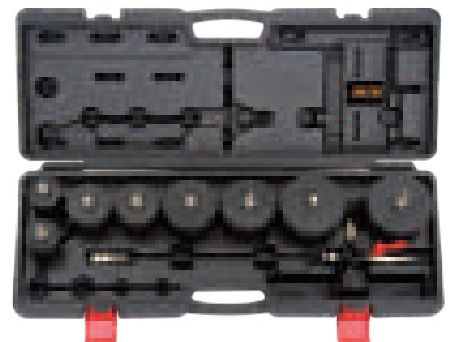

ST-23070

VALVE DISC REMOVER PLIER

- this plier is designed to release the clutch master cylinder piston rod from the clutch pedal quickly and easily.
- useful tool when removing a clutch master cylinder/pedal support bracket.
- application:
Vauxhal / Opel: Astra-J, Signum, Vectra-C/Audi: A1 (8X), A3 (8P).



ST-23100

3PCS - VALVE ADJUSTING TOOL KIT

- this set of pliers and spacer wedge has been designed for easy valve adjustment.
- the pliers to press down on the valve lifter.
- the wedge to be placed between the camshaft and valve lifter to allow the adjusting shim.
- suitable for most Toyota and Lexus / Nissan overhead camshaft engines using spacer shims.
- also for other OHC engines using spacer shims for valve adjustment; VW 5-cylinder, Audi 5000, etc.



ST-23113

2PCS - VALVE LAPPER SET

- hand grind small & large flat-head unslotted valves.
- to use place grinding compound on valve face and put in seat.
- 1pc small cup diameters: 16mm and 21mm.
- 1pc large cup diameters: 29mm and 35mm.

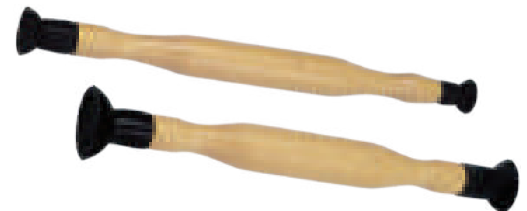

ST-23114

OVERHEAD VALVE SPRING COMPRESSOR

- it is ideal for removing valve springs, spring retainers by compressing the valve spring retainer and exposing the valve keeper, remove keepers, uncompress the tool then remove spring.
- this tool allows valve spring and valve stem oil seals to be replaced with the cylinder head.
- there are reversible jaw adaptor and automatic cam action locking to a pre-determining setting.
- with adjustable depth can fit for most large and small spring applications.
- suitable for most of OHV, OHC, CVH engines,



ST-23115

VALVE SPRING COMPRESSOR

- designed with plastic coated locking handle, when locked on keeps valve springs positively compressed during maintenance work.
- opening capacity: 72 ~ 240mm.
- adjustable collet release adaptor: 25 ~ 40mm. (dia.)
- suitable for most small and medium sized OHV engines, fully adjustable jaw with 72~240mm capacity.



ST-23116

OVERHEAD AND L-HEAD VALVE SPRING COMPRESSOR

- compresses valve springs on overhead valve and L-head engines on cars, trucks and tractors.
- throat depth 245mm and jaw opening 70~195mm fit larger engine size.
- jaws and plunger bar are easily adjusted.
- plunger bar seats on both flat and cup shaped valve heads.
- includes offset and straight jaws.

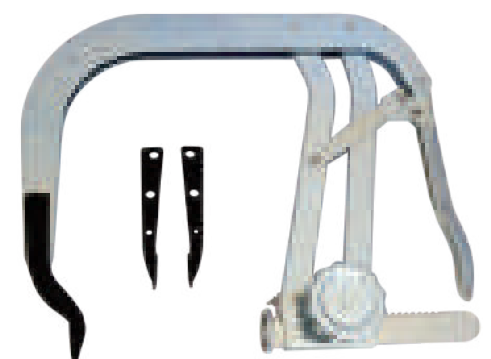

ST-23027

7PCS - VALVE SPRING COMPRESSOR KIT

- this tool kit is designed to compress and release valve spring after removing the collets.
- arched-type steel tube lever ensures a consistent coaxial contact with the valve.
- including 5 interchangeable driving adaptors to fit valve spring, 16mm, 19mm, 23mm, 25mm, 30mm.
- 2 length pressure screw: 50 mm and 90 mm.
- ideal to use on vehicles, motorcycles and small bore engines applications.
- hand-operation tool kit. ● capacity: 33 ~ 130 mm.



ST-23025

23PCS - CYLINDER HEAD SERVICE KIT

- remove and replace of worn valve spring and bushing.
- universal valve spring compressor.
- valve collet replacement tool.
- valve stem seal plier long / straight.
- valve stem seal plier long / angle.
- rigid and flexible air / cylinder hoses.
- valve stem seal replacement kit (5-6-7-8-10-11-15 mm).



ST-23056

VALVE STEM SEAL PLIER

- long stem aids removal and installation of valve stem seals on 16 and 24 valve OHC engines.
- steel plier with insulated handle. ● especially suited to stubborn seals.
- serrated tips aid grip. ● thickness 4.0 mm and 255 mmL.

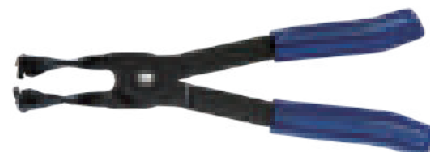

PISTON RING COMPRESSOR

ST-23033A	53~125 mm x 75 mmL.	ST-23033E	90~175 mm x 100 mmL.
ST-23033B	53~125 mm x 85 mmL.	ST-23033F	90~175 mm x 150 mmL.
ST-23033C	90~175 mm x 75 mmL.	ST-23033G	90~175 mm x 162 mmL.
ST-23033D	90~175 mm x 85 mmL.		

- two spring steel bands provide evenly distributed pressure across all piston rings.
- handles most pistons are durable and easy thumb release.
- for use on all passenger vehicles.



ST-25101

7PCS - CUP ROCKET SET

- this tool enable cups to be installed smoothly without scratching or O-ring cylinders.
- 14.4 mm ~ 16.0 mm (dia.). 24.0 mm ~ 26.0 mm (dia.).
- 15.9 mm ~ 17.5 mm (dia.). 25.5 mm ~ 27.5 mm (dia.).
- 17.5 mm ~ 19.1 mm (dia.). 30.3 mm ~ 32.3 mm (dia.).
- 20.7 mm ~ 22.4 mm (dia.).



ST-25036

SEAL PULLER

- easily to remove grease and oil seal.
- heavy-duty and heat-treated steel.
- 2 tips for multiple application.
- red vinyl, non-slip handle.



ST-29030

4PCS - MINI HOOK AND PICK SET

- ideal for installing and removing O-rings, seals and washers.
- stainless steel blades have knurled area for better finger control.
- 1pc - combination pick x 125 mmL. 1pc - straight pick x 125 mmL.
- 1pc - 90° pick x 125 mmL. 1pc - hook pick x 125 mmL.



ST-24522

3PCS - SEAL PULLER SET

- quickly and easily remove O-ring, grease and oil seal.
- special angle on the tool head provides a better work than traditional seal pullers.
- 3 different lengths and tips fit nearly all seal application.
- simple insert the tool tips, press and pull.
- contents: 117 mmL. - 150 mmL. - 165 mmL.



ST-24573

4PCS - SEAL REMOVAL TOOL SET

- round tip with blended radius edge allows to removal seals or O-ring while reducing chance of damaging to seal or finished surface.
- 2 tip configurations and 2 blade lengths handle most seal removal situations transmissions, heater & vacuum hoses, oil pump drive shaft seals, injectors and fuel rail O-ring, inner tie rod rack boot & CV boot removal, fork seals & caliper dust boot assemblies on motorcycles & steering racks on pumps.



ST-24555

REPLACEABLE OIL PAN SEPARATOR

- suitable for separating broken gasket seal on engine sump, transmission or any difficult-to-separate gasket joint.
- install the rod with tool body, then work w/a hammer to separate the gasket or joint.



ST-25040

3/8" DR. OXYGEN SENSOR RE-THREAD TOOL

- oxygen sensor re-thread tool.
- (F) 3/8" dr. x (M) M18 x 1.5P.
- use with 3/8" dr. ratchet handle or suitable wrench.

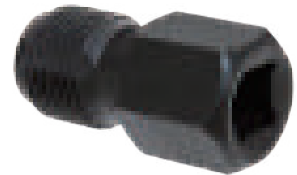

ST-25038

OXYGEN SENSOR SOCKET

- this offset oxygen sensor socket enables you to remove and install sensor on computerized engine controlled vehicles.
- the offset design helps to reach oxygen sensor in tough-to-reach spots compared to standard wrench.
- 3/8" dr. x 22mm. universal vacuum PVS,TVS, valve and oxygen sensor socket.
- use with 3/8" dr. ratchet handle or breaker bar.



ST-25039

OXYGEN SENSOR SOCKET

- special 22 mm socket with cutaway slot to provide.
- provides adequate depth to fit over sensor.
- clearance for wire harness.
- heat-treated alloy steel.
- use with 3/8" sq. ratchet handle or 24 mm spanner.

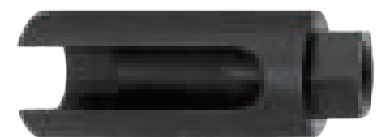

ST-23020

7PCS - OXYGEN SENSOR SWITCH SOCKET SET

- remove oxygen sensor, injector, oil pressure sending unit & vacuum switch.
- accepts either 3/8" or 1/2" dr. ratchet depending on the size of the socket.
- contents:
 - 1pc - 22mm: heated oxygen sensor socket.
 - 1pc - 22mm: low profile offset socket.
 - 1pc - 22mm: oxygen sensor socket.
 - 1pc - 27mm: oil pressure sending unit socket.
 - 1pc - 30mm: oil pressure sending unit socket.
 - 1pc - 27mm: GM thermal sensor switch socket.
 - 1pc - 22mm: universal vacuum PVS, TVS, Valve and oxygen sensor socket.



ST-23080

10PCS - OXYGEN SENSOR SWITCH SOCKET SET

- remove oxygen sensor, injector, oil pressure sending unit & vacuum switch.
- accepts either 3/8" or 1/2" dr. ratchet depending on the size of the socket.
- contents:
 - 1pc - 29mm: oil pressure sending unit socket.
 - 1pc - 22mm: universal vacuum PVS, TVS valve & oxygen sensor socket.
 - 1pc - 22mm: oxygen sensor socket. 1pc - 22mm.: injector socket.
 - 1pc - 22mm: oxygen sensor socket. 1pc - 28mm.: injector socket.
 - 1pc - 27mm: GM thermal sensor switch socket.
 - 1pc - 26mm: oil pressure sending unit socket.
 - 1pc - 22mm: low profile offset oxygen sensor socket.
 - 1pc - 22mm: long-reach vacuum switch socket.



ST-23104

14PCS - SLOTTED SPECIAL SOCKET SET

- slotted sockets in 3/8" dr.: 10, 11, 12mm x 6pt. x 46mmL.
- slotted sockets in 3/8" dr.: 13, 14, 15, 16mm x 6pt. x 64mmL.
- slotted sockets in 1/2" dr.: 17, 18, 19, 20, 21, 22, 24mm x 6pt. x 78mmL.
- for assembly of top and side wired temperature sensors, thermo switches and other components.
- also suitable for nuts and bolts of bent pipes.
- the slot width is: 7.4mm(10), 8.8mm(11), 9.1mm(12), 10.5mm(13), 11mm(14), 11mm(15), 12.3mm(16), 13.8mm(17), 14mm(18), 14.4mm(19), 14.4mm(20), 15.7mm(21), 15.7mm(22) and 16.9mm(24).



ST-23111

TWIN CAM ADJUSTABLE TIMING LOCKING TOOL

- this tool is designed to "lock" twin camshafts during timing belt removal.
- the unique design is full adjustable and will even fit sprockets which are positioned closely together e.g. Vauxhall / Opel EcoTec engines.
- it also incorporates a variable pitch feature to cover a range of sprocket diameters and tooth pitch.
- application:
 - twin cam and quad cam V engines diesel engines - camshaft to injection pump sprocket "lock".



ST-23008

8PCS - TWIN CAMSHAFT LOCKING AND SETTING TOOL KIT

- anodised aluminum chocks suitable for locking camshaft pulley on twin cam engine.
- set includes flywheel locking tools for selected PSA and GM petrol and diesel engine.
- application:
 - Citroën / Fiat / Isuzu / Lotus / MG / Peugeot / Rover / Saab / Vauxhall / VW.



ST-23072

19PCS - TWIN CAMSHAFT LOCKING AND SETTING TOOL KIT

- this kit supply with adequate tools to lock the camshaft on twin cam (multi-valve) engine in order to stop them rotating out of timed position when the timing belt is replaced and removed.
- it also provides different camshaft locking pin that can cover specific crankshaft and flywheel locking application.
- allows the service easier and reduce the risk of incorrect valve timing from taking place.
- application: Ford / Honda / Land Rover / Vauxhall / Opel.

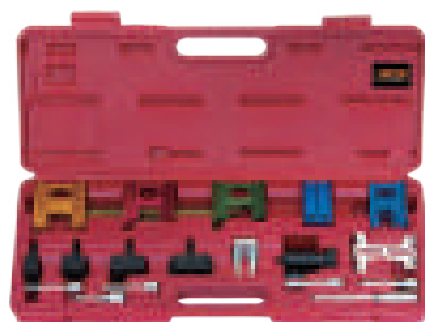

ST-23073

14PCS - VW / AUDI TIMING SETTING TOOL KIT

- this engine timing tool set is designed for VAG 2.7/3.0 TDi & TDi CR chain driven engine.
- it can be used on diesel engine fitted with four chains and tensioners linking the oil pump, crankshaft, camshaft and balance shaft.
- applicable:
VAG 2.7/3.0 Tdi V6, and 4.0/4.2 Tdi V8 chain drive. / Audi: A4, A5, A6, A8, Q5, Q7 diesel engine. / VW: phaeton, touareg diesel engine.



ST-23065

45PCS - TIMING SETTING TOOL KIT

- application Peugeot: 106/205/206/306/307/309/405/406/407/605/806/807/Expert/Partner/Boxer(AB 1986)/406 Coupe/607.
- application Citroen: AX/XZ/XM/VISA/XSARA/XANTIA/Berlingo/Jumpy/C2/C3/C5.
- application Audi: 80/A2/A3/A4/A6/Cabriolet 1995 BIS 2000).
- application Seat: Ibiza/Cordoba/Leon/Toledo/Inca/Arosa/Alhambra/Altea.
- application Sköda: Felicia/Octavia (1993 BIS 2005)/Fabia.
- application VW: Lupo/Polo/Caddy/Golf/Bora/New Beetle/Passat/Sharan/Touran.



ST-23089

CAMSHAFT HOLDING TOOL - DIESEL ENGINE

- available with 1.3L. Diesel 16V. engines.
- for counter holding the camshaft during engine timing, setting and adjustment procedure.
- application Fiat: panda/panda classic/punto/punto classic/punto evo/grande punto qubo/doblo/doblo cargo/idea/linea/fiorino/strada pick-up.
- application Lancia: ypsilon/musa/mito/ka.
- application Opel, Vauxhall, Holden: agila/agila-b/combo-c/combo-d/corsa-c corsa-d/meriva-a/meriva-b/astra-h/astra-j/tigra-b.
- application Suzuki: swift / ignis / wagon r+ / splash.
- application Peugeot: bipper. / Citroën: nemo.



ST-23082

ADJUSTABLE TIMING PULLEY PULLER

- this tool is designed for removing drive pulley with face groove.
- this tool removes a pulley absolutely free of any risk damage.
- the tool is adaptable to different pulley diameters, as the legs are adjustable.
- for removing pulley with 3, 6, 9 slots.
- surface finish: chrome plated, screw black oxide finish.
- jaw capacity: 47 mm ~ 110 mm.

ST-23066

11PCS - STRETCH BELT TOOL SET

- for mounting & dismounting stretch belt fitted to modern auxiliary belt drive system such as alternator, power steering pump, air conditioning pump and also separate water pump.
- also fits most crankshaft pulley.
- prevents damaging to the pulley & prolongs the life of the belt during installation.
- application:
BMW/Cadillac/Chevrolet/Chrysler/Citroen/Fiat/Ford/GMC/Isuzu/Iveco/Lancia/Lincoln/Mercedes Benz/Mazda/Peugeot/Volvo etc.

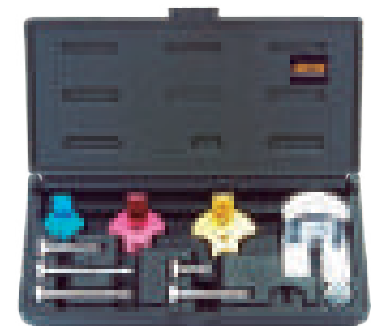

ST-23074

5PCS - BELT INSTALL TOOL SET

- specially designed set for installing the new belt onto the pulley.
- suitable for engines with elastic ribbed belt such as Romeo / BMW, Chrysler / Fiat / Ford / Mercedes Benz / PSA / Seat / Smart / Volvo / VW / Audi / Mazda / Lancia / Citroën...



ST-25041

CAM BELT TENSION GAUGE

- the schwaben micrometer-style belt tension gauge provides an exact tension measurement on any timing or accessory belt, on any vehicle.
- durable all metal construction with knurled handle and easy-to read number of measure belt tension in newton meter.



ST-25084

SONIC BELT TENSION METER

- the sonic belt tension meter is able to measure the vibration of the belt from the microphone in the front.
- the meter will then use the mathematical calculation to convert the tension from the vibration of the belt.
- which is helpful for installation or tuning of any belt.
- 20 sets frequency storage.
- maximum frequency: 600Hz.
- automatically power-off: the instrument will automatically power off when no operation for 5 minutes.
- user can also make the instrument power off by pressing on/off switch for 2 second.



ST-23112

SERPENTINE BELT REPLACE TOOL - Mercedes Benz

- designed to turn the idler and replace the serpentine belt easily.
- fit for Mercedes Benz M133 & M270 engine..
- suitable:
W176 (A class), W246 (B class), C/X117 (CLA class), X156 (GLA class).



ST-23051

5PCS - DAMPER PULLEY PULLER HOLDER WRENCH SET

- for biasing the auxiliary belt tensioner off and on during installation of the belt in the vehicle.
- the slim and curved handle is ideal for working in tight space.
- size: 13 - 15 - 16 - 17 - 19 mm.

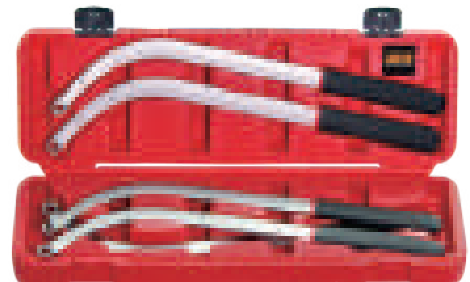

ST-23053A

10PCS - CHANGEABLE PULLEY PULLER HOLDER WRENCH SET

- for biasing the auxiliary belt tensioner off and on during installation of the belt in the vehicle.
- the slim and curved handle is ideal for working in tight space.
- changeable offset-ring type.
- 4pc - 12pt. offset-ring 12x14, 13x15, 16x17, 18x19mm.
- 5pc - E-type offset-ring E10, E12, E14, E16, E18.
- 1pc - bent handle.

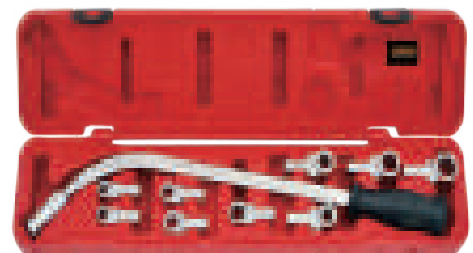

ST-23055

FLYWHEEL TURNER

- for turning and holding flexplate and flywheel.
- easily turn engine from underneath the vehicle.
- spring tension holds tool onto flywheel, allowing free use of both hands.
- great for working on clutch, transmission, installing ring or others that require the crankshaft to be in a certain position.



ST-23022

13PCS - COMPLETELY ALTERNATOR REPAIR KIT

- permits easy removal of freewheel alternator pulley, either on or off the vehicle.
- allows alternator shaft to be held while the pulley retainer is removed.
- work with hand tools or air impact wrench.
- application:
VW golf / Vento / Passat / Audi A3 / Volvo / MB A series / MB / BMW / Audi / Ford / Sköda

ST-23031

22PCS - COMPLETELY ALTERNATOR REPAIR KIT

- permits easy removal of freewheel alternator pulley, either on or off the vehicle.
- allows alternator shaft to be held while the pulley retainer is removed.
- work with hand tools or air impact wrench.
- application:
VW / Audi / Seat / Mercedes Benz / Renault / BMW / Ford / Fiat / Mercedes A series / Sköda

ST-24525

27PCS - BALANCE PULLER AND INSTALLER KIT

- built-in bearing makes balancer replacing job easy and damage-free.
- 4-slot puller plate plus 9 threaded adaptors fit to balancer or most of engine.
- for easy removal of most harmonic balancer and drive pulley which are press-fitted onto the crank-shaft.
- they easily remove the harmonic balancer & include an assortment of bolt.
- this universal kit will take care of most balancer w/threaded removal hole.
- not only remove balancer but also installs them, using the included threaded crank shaft adaptors.
- prevents damaging to the pulley and shaft.

ST-24005

6PCS - HARMONIC DAMPER PULLEY PULLER KIT

- this kit for harmonic balancer removal on Chrysler, GM, Mitsubishi vehicle when you need to remove the harmonic balancer on your vehicle.
- compatible with Chrysler, GM, Mitsubishi, Cadillac and Oldsmobile vehicle; Car, SUV, van and pickup truck.
- enhanced design with spring-loaded legs for optimal position retention; all steel construction for extra strength and longevity; black oxide finish for corrosion resistance.
- use with 3/8" dr. or 3/4" dr. wrench or socket.

ST-24643

11PCS - BLIND HOLE BEARING PULLER & SLIDE HAMMER KIT

- set for pulling blind hole bearings off in an energy saving way.
- includes a slide hammer and a claw puller.
- provided with collets for major blind hole inner diameter sizes.
- adaptor expand when being tightened.
- claw puller: M10 x 1.5 / 8~11mm collet.
- slide hammer: M10 x 1.5 - M6 x 1.0 / 12~17mm collet.
- extended adaptor:
M10 x 1.5 - M8 x 1.25 / 18~23, 24~29, 30~34mm collet.

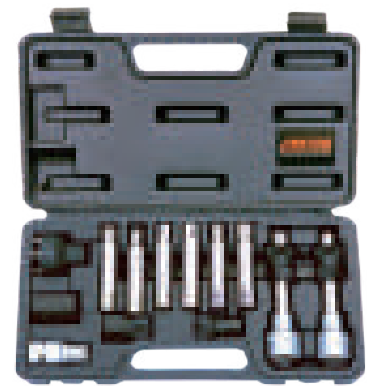

ST-24644

16PCS - BLIND HOLE BEARING PULLER & SLIDE HAMMER KIT

- set for pulling blind hole bearings off in an energy saving way.
- includes a slide hammer and a claw puller.
- provided with collets for major blind hole inner diameter sizes.
- adaptor expand when being tightened.
- claw puller: M10 x 1.5 / 8~11mm collet.
- slide hammer: M10 x 1.5 - M6 x 1.0 / 12~17mm collet.
- extended adaptor: M10 x 1.5 - M8 x 1.25 /
- collet: 18~23, 24~29, 30~34, 34~38, 39~43, 44~48, 49~53, 54~58mm.



ST-29050

TRANSMISSION OIL DIPSTICK - Mercedes Benz

- overall length: 1,220 mmL.
- this oil gauge and dipstick is designed for measuring the oil level on different vehicle of Mercedes Benz.
- suitable for 722.6 models.



ST-29051

TRANSMISSION OIL DIPSTICK - Mercedes Benz

- overall length: 920 mmL.
- this oil gauge and dipstick is designed for measuring the oil level of transmission for different vehicle of Mercedes Benz.
- reference model:
for Mercedes W210 W211 available all of E class.
for Mercedes W210 W211 available all of E class.
for Mercedes W202 W203 W204 available all of C class.
for Mercedes W168 W169 available all of A class.
for Mercedes W245 available all of B class.
for Mercedes W140 W220 available all of S class.



ST-29052

TRANSMISSION OIL DIPSTICK - Mercedes Benz

- overall length: 930 mmL.
- this oil gauge and dipstick is designed for measuring the oil level of transmission for different vehicle of Mercedes Benz.
- reference model:
C240, C320, C320amg, CLK320, E320, SLK320, SLK320amg, C55amg, CLK500, CLK55amg, E500, E55Kamg, CLS500, CLS55Kamg, S430, S500, S55amg, S55Kamg, CL500, CL55amg, CL55Kamg, SLK55amg, SL500, S600 (2000~2002), E320cdi, ML500, R500 (2006~2007).



ST-29053

TRANSMISSION OIL DIPSTICK - Mercedes Benz

- overall length: 930 mmL.
- this oil gauge and dipstick is designed for measuring the oil level of transmission for different vehicle of Mercedes Benz.
- reference model:
103 / 104 / 111 / 119 / 120 / 137 / 603 / 604 / 605 / 606 / 611 / 612 / 613 / 626 / 913 / 943 / 963 / 984 / 985 / 997 engines.

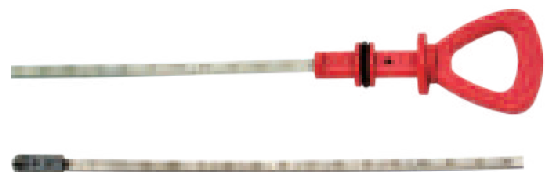

ST-29054

TRANSMISSION OIL DIPSTICK - Audi and VW

- overall length: 695 mmL.
- this oil gauge and dipstick is designed for measuring the oil level of transmission for different vehicle of Audi and VW.
- reference model:
Audi 053115611C 80 (81, 85, B2, 89, 89Q, 8A, B3, 8C, B4) A4 (8D2, B5, 8D5, B5) A6 (4A, C4) VW passat (32B, 3B2, 3B5).



ST-29055

TRANSMISSION OIL DIPSTICK - Audi

- overall length: 695 mmL.
- this oil gauge and dipstick is designed for measuring the oil level of transmission for different vehicle of Audi.
- reference model:
Audi 2.0 tfsi, 3.2 fsi. 3.0 supercharged, 4.3 fsi and 2.0 tdi cr.
Audi A4 / A5 6 cyl petrol direct injection 3.2 4V engine.

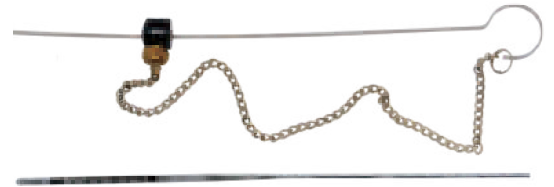

ST-29046

42PCS - UNF, UNC AND METRIC RE-THREAD KIT

- tap and dies suitable for chasing out damaged thread and removal of nick and burr without undercutting good thread.
- right or left handed thread file restores damaged external thread on any diameter, just select the correct pitch.
- rethreader die size:
1/4", 5/16" 3/8", 7/16", 1/2", 9/16" and 5/8", UNC
1/4", 5/16" 3/8", 7/16", 1/2", 9/16" and 5/8", UNF
6x1.00, 8x1.25, 10x1.25, 10x1.50, 12x1.25, 12x1.50, 12x1.75mm.
- rethreader tap size: 1/4", 5/16" 3/8", 7/16", 1/2" and 9/16", UNC
1/4", 5/16" 3/8", 7/16", 1/2" and 9/16", UNF
6x1.00, 8x1.25, 10x1.25, 10x1.50, 12x1.25, 12x1.50, 12x1.75mm.
- description pitch size: SAE file 11, 12, 13, 14, 16, 18, 20 & 24.
SAE file 9, 10, 12, 16, 20, 27, 28 & 32.



ST-29047

25PCS - DAMAGED BOLT EXTRACTOR KIT

- suitable for the removal of broken stud and bolt.
- supplied with centring pilot for 4.75 ~ 9.75mm (dia.) stud, drill, extractor shafts and nut.
- ideal for engine manifold stud.
- drill size: 3.2, 4.8, 6.4, 8, 8.7 mm.
- minimum stud size: 4.75 mm.
- maximum stud size: 15 mm.



ST-29063

ADJUSTABLE TAP SOCKET

- designed for use with taps, reamers, screw extractors and other tools with a square shank.
- two sections design fits common tap from M4 ~ M14.
- fit all 3/8" square drive tools or 19mm spanner.
- for use in tight workspaces.



ST-29002

21PCS - TAP AND DIE KIT

- this tap and die set contains everything you need to repair and cut internal and external thread and is machined to exacting standard.
- 18pc - tap and die: M3x0.5/M4x0.7/M5x0.8/M6x1.0/M7x1.0/M8x1.25/M10x1.5/M12x1.75/1/8"xNPT27.
1pc - die handle. 1pc - screw-driver. 1pc - adj. tap wrench.

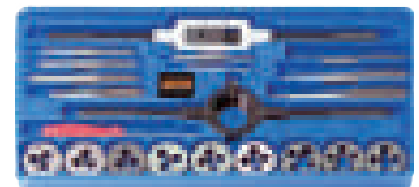

ST-29012

39PCS - TAP AND DIE KIT

- this tap and die set contains everything you need to repair and cut internal and external thread and is machined to exacting standard.
- 34pc - tap and die:
M3x0.5/M3x0.6/M4x0.7/M4x0.75/M5x0.8/M5x0.9/M6x0.75/M6x1.0/M7x1.0/M8x1.0/M8x1.25/M10x1.25/M10x1.5/M12x1.5/M12x1.75/1/8"xNPT27.
1pc - tap wrench. 1pc - screw pitch gauge.
1pc - "T" - tap wrench. 1pc - screw-driver.
1pc - die stock 25mm.



ST-29043

51PCS - TAP AND DIE KIT

- this tap and die set contains everything you need to repair and cut internal and external thread and is machined to exacting standard.
- 20pc - tap: M6x1.0/M6x0.75/M8x1.25/M8x1.0/M10x1.5/M10x1.25/M12x1.75/M12x1.5/M14x2.0/M14x1.5/M16x2.0/M16x1.5/M18x2.5/M18x1.5/M20x2.5/M20x1.5/M22x2.5/M22x1.5/M24x3.0/M24x1.5.
- 14pc - 1-1/2" (od) die: M6x1.0/M6x0.75/M8x1.25/M8x1.0/M10x1.5/M12x1.75/M12x1.5/M14x2.0/M14x1.5/M16x2.0/M16x1.5/M18x2.5/M18x1.5.
- 6pc - 2" (od) die: M20x2.5/M20x1.5/M22x2.5/M22x1.5/M24x3.0/M24x1.5.
- 5pc - screw extractors: #1, #2, #3, #4, #5.
- 2pc - 2" (dia.) die stock with 1-1/2" adaptor. 1pc - T type tap wrench.
- 1pc - automatic punch. 1pc - tap wrench.



ST-29039

75PCS - TAP AND DIE KIT

- this tap and die set contains everything you need to repair and cut internal and external thread and is machined to exacting standard.
- 68pcs - tap and die: M3x0.5/M3x0.6/M4x0.7/M4x0.75/M5x0.8/M5x0.9/M6x1.0/M7x1.0/M8x1.25/M9x1.0/M9x1.25/M10x1.25/M10x1.5/M11x1.5/M12x1.5/M12x1.75/1/8BSP28/4NC40/6NC32/8NC32/10NC24/10NF32/12NC24/1/4NC20/1/4NF28/5/16NC18/5/16NF24/3/8NC16/3/8NF24/7/16NC14/7/16NF20/1/2NC13/1/2NF20/1/8NPT27. 2pc - tap holder (M3-M6) (M6-M12).
- 1pc - gear wrench. 2pc - screw pitch gauge.
- 1pc - die stock. 1pc - screw-driver.

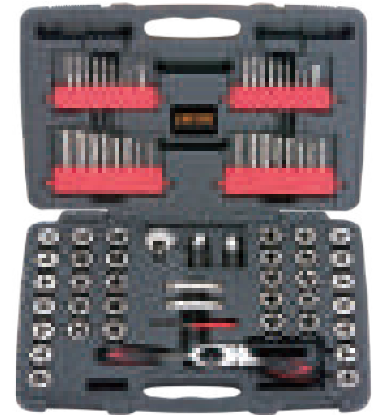

ST-29027

20PCS - FEELER THICKNESS GAUGE SET

- the gauge contains 20 blades, which are made of high quality carbon steel.
- the blade is from 0.05 ~ 1.00 mm.
- blade thickness: 0.05 mm. 0.10 mm. 0.15 mm. 0.20 mm. 0.25 mm. 0.30 mm. 0.35 mm. 0.40 mm. 0.45 mm. 0.50 mm. 0.55 mm. 0.60 mm. 0.65 mm. 0.70 mm. 0.75 mm. 0.80 mm. 0.85 mm. 0.90 mm. 0.95 mm. 1.00 mm.

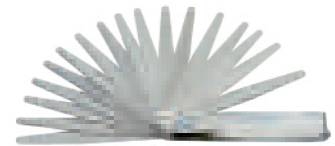

ST-29040

12PCS - THREAD GAUGE SET - METRIC

- a simple device for checking the pitch of screw thread, particularly useful when trying to identify threaded item like bolt and screw.
- one end has a range of imperial pitch and the other has metric.
- suitable for thread size: 0.5 / 0.6 / 0.7 / 0.75 / 0.8 / 0.9 / 1.0 / 1.25 / 1.5 / 1.75 / 27 / 28.



ST-29041

12PCS - THREAD GAUGE SET - SAE

- a simple device for checking the pitch of screw thread, particularly useful when trying to identify threaded items like bolts and set screws.
- one end has a range of imperial pitches and the other has metric.
- suitable for thread size: 12/13/14/16/18/20/24/27/28/32/36/ 40.

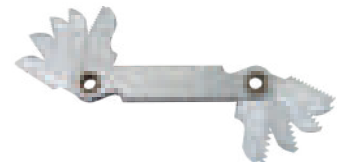

ST-25502

ENGINE LOAD LEVELER

- more available space w/extended fix base for engine rubber damper and metal bush replacement.
- two hooks & chains for securely hoisting all kind of engine & transmission.
- stand on the inner wall and acting as a bridge to support engine.
- adjustable in height & width to bridge all vehicles' fender wall and securely hold engine in place.
- including slider bolt that can be positioned to anywhere on the bar weight balance.



ST-25068

BATTERY TERMINAL AND WIPER PICK UP TOOL

- to work for battery terminal and windshield wiper etc
- the tights at terminal will be lifted off without damage the battery case or posts, because the sharp jaws are able to engage either below or on the side of terminal.
- travel: 100 mmL.



ST-25073

UNIVERSAL BATTERY CARRIER

- designed to lift large size of battery.
- the steel handle and adjustable arm, have rubber pad, that are riveted and glued to each end to provide an exceptional grip.
- the carrier is built with a non-slip vinyl hand grip for superior support.
- capacity from 133 to 190 mmL.



ST-25054

12 / 24 VOLT AUTO. MANUAL BATTERY CHARGER

- charger provides extra versatility with both high/low charging rate and two major operating systems.
- input power: 12 / 24 volt.
- engine start: 12 volt - 100A.
- battery: Reg / AGM / Maintainer free.
- charger rate: 12 volt - 15A. / 2A. 24 volt - 8A.



ST-25072

12 VOLT BATTERY CHARGER

- this charger use microprocessor to monitor the charger process.
- therefore it is a smart charger with protection of reverse connection, over-voltage, over-current, short circuit, and over-charging.
- it has wide working temperature, and it has IP54 protection.
- input voltage: 100 ~ 240V.
- output voltage: 12 volt.
- charging voltage: 12 volt.
- charging current: 3.8A.
- battery capacity: 6 ~ 120Ah.



ST-25048

BATTERY TESTER

- insert tester into cell of the battery.
- hold the tester vertically, squeeze fluid into tester.
- the number of balls floating indicates battery condition.
- return liquid to the same battery cell from which it was drawn.



ST-25056

BATTERY TESTER

- avoid dead batteries and helps to extend battery life.
- tests battery life hot or cold detects overcharge.
- tests all 6 - 12 - 24 volt system.

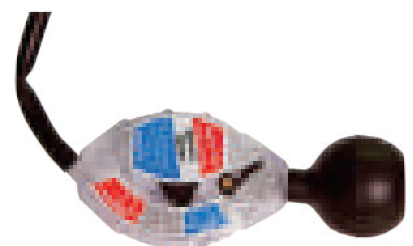

ST-25020

ANALOGUE MULTIMETER

- a reliable 20,000V DC multimeter with diode and fuse protection, mirror scale, dB reading and transistor checker.
- DCV: 0 - 0.1 - 0.5 - 2.5 - 10 - 50 - 250 - 1000 V.
- ACV: 0 - 10 - 50 - 250 - 1000 V.
- DCA: 0 - 50 μ A - 2.5 mA - 0.25 A.



ST-25087

12V. VEHICLE BATTERY TESTER

- available range of cold cranking ampere: DIN 105~600
- 3-funcions: battery test, engine starting voltage test and charging voltage test.
- available with sealed maintenance free battery, maintenance free battery, standard type battery, enhanced flooded cell battery and absorbent glass mat battery.
- range of cold: 0.01V. / 1CCA.
- accuracy: +/- 005V.
- reverse ploarity protection: <20V. DC



ST-25088

20A. CAR CURRENT TESTER

- this is a stable, low power consumption, and high accuracy 3 1/2 digits (2000 counts) leaking current meter for automobile.
- leaking current for automobile is generally as small as milliamps, which is hard to measure by clamp meter.
- by plug this meter with the fuse box, user is able to measure leaking current as small as 1 mA.
- refresh rate: 3-times per seconds.
- power: 1.5V. AAA battery x 2pcs.
- measure range: 0 ~ 20A.



auto range	accuracy	resolution
1999 mA.	2digits +/-0.5%	10 mA.
20 A.	2digits +/-0.5%	10 mA.

ST-25089

12V. / 24V. RELAY TESTER

- figure out the condition of the relay.
- speculating the problem in the vehicle.
- power supplied: 12V. / 24V. Vehicle battery.
- vehicle relay testing for 3 most popular kind of relays.
- suitable for 12V. / 24V. vehicle relay.
- health test for 4 and 5-pin electro-mechanical relays commonly found on modern vehicles.
- testing the resistance, contacts and consistency within each cycle.



ST-25063

20A. AUTO CURRENT TESTER

- range: 0 ~ 20 A. / 0 ~ 48 Vdc.
- max. load: 20 A / 48 Vdc for max. 10 sec.
- accuracy: +2% reading + 2 digits.
- relative humidity: < 70% operating, < 80% storage.
- operating altitude: 2000 meters (maximum).
- operating temp.: 0°C ~ 50°C.
- storage temp.: -20°C ~ 60°C.



ST-25111

THE OPTIMAL AUTO CIRCUIT TESTER

- this is an equipment used to test the automotive electrical system within 12 ~ 24 volt.
- in order to save the testing time for the automotive electrical system, it is designed to test the system w/out re-connection between the vehicle battery and the testing component, and it contains the above function.
- testing the voltage of the circuit and the voltage reading will be indicated on the LCD display within 1/10th of a volt.
- 4-function:

measuring voltage range: 0~60 volt.	measuring rotational speed.
locate missing cylinder.	peak detection.



ST-25061

12V. DIGITAL BATTERY ANALYZER

- the analyzer can be hung on the wall or place standing on the table with back and side special hook design.
- covered with removable & washable grey soft case.
- stable quality, shaking-resistant and portable can be installed on different kinds of vehicle battery for testing.
- max. opening of clinchers: 360° of angle.
- based on sonar reflection principle, all the indexes of battery are analyzed by special alternating current signals which lead to very accurate testing result.



ST-25071

12V. AUTO BATTERY AND CHARGING SYSTEM ANALYZER

- auto battery analyzer checks battery, regulator and alternator.
- for all 12 volt system vehicle, with LED indicator that helps pinpoint problem for fast trouble shooting.



ST-25009

12V. BATTERY ALTERNATOR CHECKER

- easy to operate with LED light to show.
- battery charge situation.
- high or low output of alternator.



ST-25047

BATTERY HYDROMETER

- squeeze bulb and draw up enough liquid until float moves freely but do not touch rubber stopper at top barrel.
- insert rubber tip in cell of battery.
- hold instrument in vertical position.
- the mark on the battery tester which is in line with the surface of liquid indicates condition of battery thus:

RED - 1.100~1.205 battery cell is in discharged.
WHITE - 1.205~1.260 battery cell needs attention.
GREEN - 1.260~1.300 battery cell is OK.



ST-25022B

MEMORY BACK-UP

- this power backup offer backup power to the vehicle via OBD II connector while changing the battery.
- power backup work on all vehicle types, it also can protect the MIS polarity.

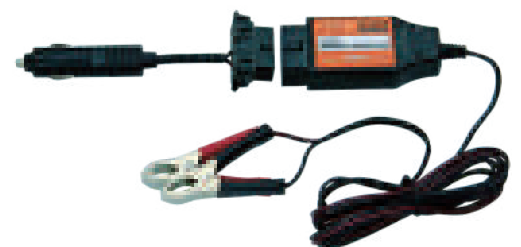

ST-25070A

AUTO CIRCUIT TESTER

- circuit tester with test lead for either passenger vehicle or truck.
- automotive voltage tester with range 3 ~ 48 VDC.
- tail with banana connector, additional crocodile clip and testing probe for testing connection.
- pierce through clip for cable < 4 mm.
- cable length 100 cm.



ST-25070B

AUTO CIRCUIT TESTER

- circuit tester with test lead for either passenger vehicle or truck.
- automotive voltage tester with range 3 ~ 48 VDC.
- tail with crocodile clip and testing probe for testing connection.
- pierce through clip for cable < 4 mm.
- cable length 100 cm.



ST-25055

6 - 12 - 24 VOLT AUTO CIRCUIT TESTER

- use this tester to check all 6~24 volt circuit and accessories including light, starter, alternator, cooling and heating component, radio and relay.
- not recommend to use on computer, sensor or computer wiring.
- consult the service manual for circuit diagram and specific test procedure.



ST-25049

6 - 12 - 24 VOLT AUTO CIRCUIT TESTER

- the most essential tool for trouble auto. Shooting electrical system.
- make it easy to find out where current is present.
- super-sharp probe punctures wire insulation easily.
- long lead for convenience.



ST-25066

6 - 12 - 24 VOLT DIGITAL DISPLAY AUTO CIRCUIT TESTER

- digital display to read the accurate voltage value.
- available for 6, 12, 24 VDC system.
- LED indicator for power (red) and ground (green).
- stainless steel testing probe.
- voltage measurement from 5 ~ 28 V.
- small testing current < 10 mA.
- 3 meter spring cable.



ST-25074

6 - 12 - 24 - 48 VOLT DIGITAL DISPLAY AUTO CIRCUIT TESTER

- digital display to read the accurate voltage value.
- available for 6, 12, 24 & 48 VDC system.
- LED indicator for power (red) and ground (green).
- stainless steel testing probe.
- voltage measurement from 4 ~ 60 V.
- small testing current < 10 mA.
- 3 meter spring cable.



ST-25065

VEHICLE ACTUATOR TESTER

- this device is designed to test electronic component actuate by magnetic field or electronic magnetic field.
- devices like actuator, ignition coil, AC generator, indoor air blower, valve controller EGR (exhaust gas control), injector, spark plug, relay, and hall effect sensor are such which can be tested.



ST-21001

12 VOLT BATTERY SURGE PROTECTOR

- this unit is designed to prevent damaging voltage spikes and surges reaching delicate vehicle's electronic system.
- clips across the battery terminals & permits working such as body welding without effecting or damaging electronic device system.
- time of answering: 10~12 sec.
- input voltage: DC 12 volt.



ST-21002

24 VOLT BATTERY SURGE PROTECTOR

- this unit is designed to prevent damaging voltage spikes and surges reaching delicate vehicle's electronic system.
- clips across the battery terminals & permits working such as body welding without effecting or damaging electronic device system.
- time of answering: 10~12 sec.
- input voltage: DC 24 volt.



ST-21003

12 / 24 VOLT BATTERY SURGE PROTECTOR

- this unit is designed to prevent damaging voltage spikes and surges reaching delicate vehicle's electronic system.
- clips across the battery terminals & permits working such as body welding without effecting or damaging electronic device system.
- time of answering: 10~12 sec.
- input voltage: DC 12/24 volt.



ST-25062

FAST CHECK WIRE-CLIP

- applicative wire diameter: 1.5 mm ~ 4.5 mm.
- voltage range: 0 V ~ 330 V.
- current load: max. 5 A.



ST-25067

13PCS - PROBE AND TEST ADAPTOR SET

- high quality testing and test accessories.
- for use in conjunction with test probe.
- bi color test leads for polarity indication.
- 2pc - male/female to female/male extension wire.
- 1pc - insulator pierce through clip.
- 2pc - polarity tester / stroboscope.
- 2pc - alligator clip.
- extra thin test probe.
- flexible silicone cable.
- 2pc - testing probe.
- 4pc - testing needle.



ST-25083

50 WATT CORDLESS HEATING TOOL

- powerful soldering iron for general industrial / automotive applications.
- cordless soldering, without the need for butane refills.
- fast 10 second start up / 600°C max temperature with 60 seconds.
- one charge provides 40 minutes continuous runtime.
- supplied with cone / chiset tips. optional tips available separately.
- simple USB recharging (charging time 3 hours).
- 2,000mAh lithium-ion battery.



ST-25116

10PCS - GAS INDEX SOLDERING IRON KIT

- professional 3-in-1 soldering iron / torch / hot blower with 7 accessories (chisel tip, anvil tip, flat tip, deflector, lead free soldering wire, cleansing sponge, hot knife blade and base).
- index head for 3-different angles and can be operated in each angle while work, for different applications.
- 90 ~ 150 watt equivalent electrical power.
- burning time: 45 ~ 60 min.
- fuel type: butane (normal lighter gas).
- gas volume: 30 mL.
- flame temperature: 1,300 °C.
- soldering temperature: 450 °C.
- hot air temperature: 600 °C.



ST-25069

RELAY REMOVAL PLIER

- plier for removing electrical relay on most of vehicle.
- offset handle and thin tip allows access to relay in confined area.



ST-25090

ELECTRICAL CONNECTOR DISCONNECT PLIER

- designed with sharp tip.
- special angle designed can avoid obstacles.
- quickly disconnects electrical connectors without damage.
- releases locking tabs on electrical connectors, component connections and wiring harness connectors.
- the safe and easy way to remove small, thin or recessed connector that's difficult to work with.



ST-25091

ELECTRICAL CONNECTOR DISCONNECT PLIER

- designed with better grip tip.
- special angle designed can avoid obstacles.
- quickly disconnects electrical connectors without damage.
- releases locking tabs on electrical connectors, component connections and wiring harness connectors.
- the safe and easy way to remove small, thin or recessed connector that's difficult to work with.

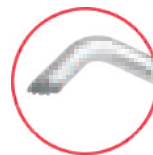

ST-25007

WIRE STRIPPER AND CUTTER

- designed with wire stripping and wire cutting function.
- capacity of stripped insulating layer: 9.5 mm (dia.)
- capacity of wire cutting: 0.2 - 0.3 - 0.4 - 0.5 - 0.6 - 0.8 mm (dia.).

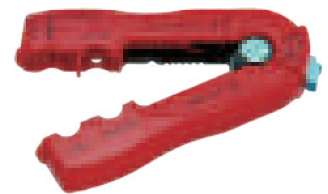

ST-25008

WIRE STRIPPER AND CUTTER

- designed with wire stripping and wire cutting function.
- capacity of stripped insulating layer: 9.5 mm (dia.)
- capacity of wire cutting: 0.8 - 1.0 - 1.3 - 1.6 - 2.0 - 2.6 mm (dia.).

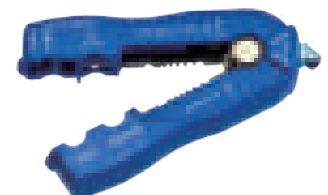

ST-25076

MULTI-FUNCTION CRIMPING TOOL

- designed with wire stripping and wire cutting function.
- capacity of stripped insulating layer: 0.2 ~ 6.0 mm. (dia.)
- capacity of wire cutting: 0.2 ~ 6.0 mm. (dia.)

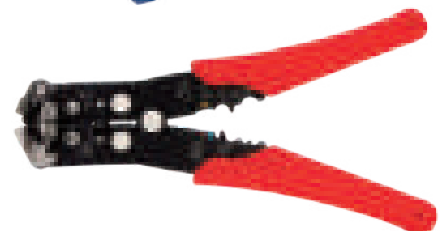

ST-24574

12" AUTO-ADJUSTING OIL FILTER WRENCH

- jaw auto-adjust with one hand operation.
- layered steel construction for added strength.
- non-slip shaped cushioned grip for comfort.
- remove filter from 60mm to 120 mm (dia.).
- fits most oil filter.

**OIL FILTER WRENCH**

ST-24548A capacity: 60 mm to 90 mm (dia.).

ST-24548B capacity: 85 mm to 115 mm (dia.).

- three-position slip joint design quickly adjusts to size.
- right-angle teeth grip while turning in either direction.
- long handle reach into tight space.
- soft, comfortable grip offer non slip control.
- fits most of oil filter.

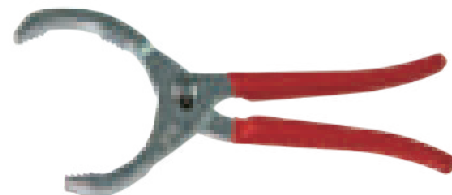
**3-STEP OIL FILTER WRENCH**

ST-24550A capacity: 60 mm to 75 mm (dia.).

ST-24550B capacity: 75 mm to 95 mm (dia.).

ST-24550C capacity: 95 mm to 115 mm (dia.).

- jaw have multiple teeth designed.
- drop forged steel construction.
- the automatic action clamping ring has a serrated inner surface for a secure grip.
- fits most of oil filter.

**STEEL BAND OIL FILTER WRENCH**

ST-24600A capacity: 60 mm to 73 mm (dia.).

ST-24600B capacity: 73 mm to 85 mm (dia.).

ST-24600C capacity: 85 mm to 95 mm (dia.).

ST-24600D capacity: 95 mm to 111 mm (dia.).

- get into tight engine bay spot and grip on the dirtiest of filter.
- extra-thick yoke for added strength, can be applied at 180° to the filter.
- wide dimpled band securely grips filter without crushing.
- fits most of oil filter.



ST-24553

CHAIN OIL FILTER WRENCH

- this wrench is made of steel and is a universal one for most of the metal oil filter.
- it is used to unscrew the oil filter where there is limited access.
- chain length: 480 mm.
- removes filter maximum: 130 mm (dia.).
- fits most of oil filter.

**HEAVY-DUTY CHAIN OIL FILTER WRENCH**

ST-24654A capacity: 60 mm to 105 mm (dia.).

ST-24654B capacity: 60 mm to 160 mm (dia.).

- this wrench is made of steel and is a universal one for most of the metal oil filter.
- it is used to unscrew the oil filter where there is limited access.
- fits most of oil filter.

**HEAVY-DUTY CHAIN OIL FILTER WRENCH**

ST-24655A capacity: 60 mm to 115 mm (dia.).

ST-24655B capacity: 60 mm to 170 mm (dia.).

- this wrench is made of steel and is a universal one for most of the metal oil filter.
- it is used to unscrew the oil filter where there is limited access.
- fits most of oil filter.



ST-24664

TRANSMISSION OIL FILTER WRENCH

- used when removing and installing the oil filter of the BorgWarner (Haldex) clutch.
- 5mm hex key wrench for drain plug.
- available with 02C and 02M transmission.
- suitable for:
VW: beetle, bora, golf, jetta, sharan.
Audi: TT, TTS, A3, S3 .
Skoda: octavia / Seat: alhambra, leon, toledo.



ST-24027

1/2" DR. OIL FILTER SOCKET

- used to remove fuel filter.
- suitable for Mitsubishi fuso cantar 4P10 diesel engine 3.5T, 6.7T & 6.9T.
- operation with 1/2" dr. wrench.
- capacity: 50mm.



ST-24008

VAG FUEL FILTER COVER MOUNTING TOOL

- this fuel filter cover mounting tool is designed to press the fuel filter cover evenly and in a torsion-free manner into the seal in the fuel filter housing.
- this tool avoids distortion of the filter plate and housing which can create ongoing dangerous fuel leak.
- suitable for VAG diesel vehicle fitted with UFI or MANN filter.



ST-24006

3/8" DR. SPIDER OIL FILTER WRENCH

- gear-driven and heat-treated leg will handle high torque application.
- removes filter from 63 mm to 102 mm (dia.).
- (m) 3/8" dr. x (f) 1/2" dr. adaptor included.
- use with 3/8" or 1/2" dr. ratchet handle or 21 mm spanner.



ST-24563

3/8" DR. SPIDER OIL FILTER WRENCH

- gear-driven and heat-treated leg will handle high torque application.
- removes filter from 45 mm ~ 111 mm (dia.).
- (m) 3/8" dr. x (f) 1/2" dr. adaptor included.
- use with 3/8" or 1/2" dr. ratchet handle or 21 mm spanner.



ST-24564

3/8" DR. REVERSIBLE OIL FILTER WRENCH

- special designed to remove and tighten most of oil filter.
- quick and easy to change the direction.
- steel jaw grip filter without slipping.
- removes filter from 61 mm ~ 97 mm (dia.).
- use with 3/8" dr. ratchet wrench.



ST-24585

3/8" DR. ALUMINUM OIL FILTER WRENCH - MERCEDES BENZ

- 14 flutes x 84.4 mm x 3/8" dr. x 46 mm (h.).
- max. torque: 25 Nm.
- use with 3/8" dr. ratchet handle or 27 mm spanner.
- application: Dodge Sprinter 2007~2018 / Jeep Cherokee with 3.0L V6 Diesel Engines 2007 / Mercedes Benz OM642 V6 Diesel 2007~2018.



ST-24586

3/8" DR. ALUMINUM OIL FILTER WRENCH - LAND ROVER

- 15 flutes x 90.2 mm x 3/8" dr. x 66 mm (h.).
- max. torque: 25 Nm.
- use with 3/8" dr. ratchet handle or 27 mm spanner.
- application: Land Rover: LR4 2014~2019 / Range Rover 2014~2019 / Range Rover Sport 2015~2019.



ST-24587

3/8" DR. ALUMINUM OIL FILTER WRENCH - TOYOTA AND LEXUS

- 14 flutes x 64.5 mm x 3/8" dr. x 47 mm (h.).
- max. torque: 25 Nm.
- use with 3/8" dr. ratchet handle or 27 mm spanner.
- application: Toyota: 4 Runner 2010~2016 / Avalon 2006~2018 / Camry 2006~2018 / Highlander 2008~2018 / Land Cruiser 2008~2017 / RAV 4 2010~2018 / Sequoia 2008~2017 / Sienna 2007~2019...
Lexus IS460 2007~2017 / LX570 2008~2017 / RX350 2007~2018...



ST-24588

3/8" DR. ALUMINUM OIL FILTER WRENCH - TOYOTA

- 14 flutes x 64.5 mm x 3/8" dr. x 47 mm (h.).
- max. torque: 25 Nm.
- use with 3/8" dr. ratchet handle or 27 mm spanner.
- application: Camry 4 cyl 1990~2015 / Corolla 2009~2015 / Matrix 2009~2015 / Prius 2007~2018 / Tundra 2007~2008...



ST-24589

3/8" DR. ALUMINUM OIL FILTER WRENCH - HYUNDAI AND KIA

- 15 flutes x 88.8 mm x 3/8" dr. x 51 mm (h.).
- max. torque: 25 Nm.
- use with 3/8" dr. ratchet handle or 27 mm spanner.
- application: Hyundai: Azera 2005~2010 / Entourage 2006~2008 / Genesis 2008~2014 / Santa Fe 2006~2009...
Amanti 2007~2009/Sedona 2007~2008/Sorento 2007~2009..



ST-24590

3/8" DR. ALUMINUM OIL FILTER WRENCH - VOLVO

- 16 flutes x 86.6 mm x 3/8" dr. x 74.5 mm (h.).
- max. torque: 25 Nm.
- use with 3/8" dr. ratchet handle or 27 mm spanner.
- application: S60 2006~2009 / S80 2006~2010 / V70 2006~2007 / XC70 2006~2007 / XC90 2006~2014...



ST-24591

3/8" DR. ALUMINUM OIL FILTER WRENCH - BMW

- 16 flutes x 86.6 mm x 3/8" dr. x 54 mm (h.).
- max. torque: 25 Nm.
- use with 3/8" dr. ratchet handle or 27 mm spanner.
- application: 320i xDrive 2013~2016/328i GT xDrive 2014~2016/ 335i x Drive 2007~2015 / 428i xDrive 2014~2016 / 535i xDrive 2008~2016/640i xDrive 2012~2018/Active Hybrid 52012~2016/ M2 2016~2019/M3/M4 2015~2018/X5/X6 2007~2018...



ST-24592

3/8" DR. ALUMINUM OIL FILTER WRENCH - FORD AND MAZDA

- 14 flutes x 74.2 mm x 3/8" dr. x 46 mm (h.).
- max. torque: 25 Nm.
- use with 3/8" dr. ratchet handle or 27 mm spanner.
- application: Ford Galaxy 2006~2015 / Mondeo V Turnier 2015~2019 / Ranger 2011~2019 / S-Max 2006~2014.
Mazda: 6 Break 2013~2019.

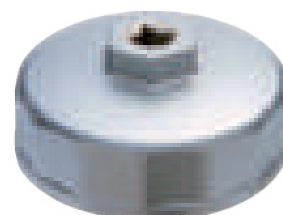

ST-24593

3/8" DR. ALUMINUM HEXAGON OIL FILTER WRENCH

- Hex 27 mm x 3/8" dr. x 30 mm (h.).
- use with 3/8" dr. ratchet handle.
- application: BMW 328d (F30) 2014~2017 / 535d (F10) 2014/2017.
Chevrolet Colorado Diesel 2016~2019.
GMC Canyon Diesel 2016~2019.
Ford Focus TDCi 2004~2011.



ST-24594

3/8" DR. ALUMINUM HEXAGON OIL FILTER WRENCH

- Hex 32 mm x 3/8" dr. x 31 mm (h.).
- use with 3/8" dr. ratchet handle.
- application: Audi A3 2015~2016 / A8 2014~2015 / Q5 2014~2015.
Porsche Cayenne Diesel 2013~2015.
VW Beetle, Golf, Jetta, Passat 2015~2016 / Touareg 2013~2016.



ST-24595

3/8" DR. ALUMINUM HEXAGON OIL FILTER WRENCH

- Hex 36 mm x 3/8" dr. x 32 mm (h.).
- use with 3/8" dr. ratchet handle.
- application: BMW 710iL 1993~2001 / 540i 1997~2003 / X5 2000~2003.
Ford F250 2003~2007 / F350 2003~2007.
VW Beetle 2006~2013 / Golf 2010~2013 / Jetta 2005~2013 / Passat 2007~2013.



ST-24623

7PCS - 3/8" DR. ALUMINUM OIL FILTER CAP WRENCH SET

- a comprehensive set oil filter wrench for removing both cartridge oil filter cover and oil filter canister.
- work with a 3/8" dr. ratchet wrench.
- application: Cadillac 36. / Mercedes A class / VW 2.8L, 3.2L, 3.6L, V6 / Cadillac cts, sts, srx / Buick rendezvous ultra, lacrosse cxs / Saturn L3000 / Saab 9-5 / Mercedes 1.8L. / Dodge cummins fuel filter housing / 2.2 Saturn ecotec / Saab / GM / Mini Cooper / BMW / mack truck / Vauxhall / Vectra / Korean brand car.



ST-24596

9PCS - 3/8" DR. ALUMINUM OIL FILTER CAP WRENCH SET

- a comprehensive set oil filter wrench for removing both cartridge oil filter cover and oil filter canister.
- work with a 3/8" dr. ratchet wrench or 27 mm spanner.
- application: Volkswagen VR6 engine. Volvo all model except 40 & 50 serie. Hyundai V6 engine. Kia V6 engine. Dodge sprinter 2007. Opel Vauxhall 4 cylinders. Jeep Cherokee 3.0L. V6 diesel engine 2007. Mercedes E320 / V6 & V8 engine / OM364 / OM366 / diesel engine OM604 OM605 OM606. Land Rover LR4 / Range Rover / Range Rover Sport. Toyota Avalon Camry 2007 / Fortuner 2005 / Hilux 2005 / Land Cruiser 2008 / Rav4 2007 / Sequoia 2008 / Sienna 2007 / Tundra 2007 / Auris 2012 / Avensis 2010 / 2009 / Camry 2010 / Corolla 2009 / Highlander 2009 / Prius 2010 / Rav4 2009 / Sienna Wish 2011. Lexus ES350 2007 / GS450h 2007 / LS 600h 2008. GM 2.2 liter Ecotec X10XE / X12XE / Y17DT / Y17DTL engine. BMW 335i 3.0L. Twin Turbo / 535i 3.0L. Twin Turbo / 3 serie (E90) / X6 3.0L. Twin Turbo / engine M52 6 cyl, M60 8 cyl, M70 12 cyl. Ford Focus 2004~2006 / Focus TDCI 1.6L. & 2.0L. 2004~2011 / Pickup.



ST-24661

23PCS - 1/2" DR. ALUMINUM OIL FILTER CAP WRENCH SET

- 901: 64mm. x P-14 - Toyota / Nissan / Fiat / Daihatsu.
- 902: 67mm. x P-14 - Ford / Mitsubishi / Mazda / Proton / Honda / Subaru.
- 903: 74mm. x P-14 - VW / Mercedes / BMW / Opel / Audi / Austin.
- 903-1: 75mm. x P-15 - GM AC / Wix / Ford / Isuzu.
- 903-2: 74mm. x P-8 - VW / Audi / Seat / BMW / Renault.
- 903-3: 74mm. x P-15 - Audi / Rover / Chrysler.
- 903-4: 73mm. x P-14 - Toyota / Lexus / Nissan.
- 903-5: 73mm. x P-30 - GM / Ford.
- 904: 78.5mm. x P-15 - Nissan / Ford / Daihatsu.
- 905: 73mm. x P-15 - GM / Chrysler / Mitsubishi.
- 906: 84mm. x P-18 - Peugeot / Citroën / Renault.
- 907: 89mm. x P-15 - Mitsubishi / Toyota / Honda.
- 908: 91mm. X P-15 - Nissan / Toyota.
- 909: 92mm. x P-15 - Honda / Toyota.
- 910: 95mm. x P-15 - Toyota / Alfarome / Ford / Chrysler.
- 910-1: 91mm. x P-12 - Citroen / Peugeot / Renault.
- 911: 76mm. x P-12 - Ford / Mazda / Mitsubishi / Daihatsu.
- 911-1: 78.5mm. x P-15 - Toyota / Honda / Nissan.
- 912: 86mm. x P-14 - Mitsubishi / Mazda.
- 913: 91mm. x P-15 - GM / Ford / Chrysler / Lancia / Fiat.
- 914: 101mm. x P-15 - Mazda / Toyota / Daihatsu / Mitsubishi.



ST-24001

3PCS - 3/8" DR. OIL FILTER CAP WRENCH SET

- a comprehensive set oil filter wrench for removing both cartridge oil filter cover and oil filter canister.
- work with a 3/8" dr. ratchet wrench.
- 27mm-6 flutes - 1 step. 32mm-6 flutes - 1 step. 36mm-6 flutes - 1 step.



ST-24003

14PCS - 3/8" DR. OIL FILTER CAP WRENCH SET

- a comprehensive set oil filter wrench for removing both cartridge oil filter cover and oil filter canister.
- work with a 3/8" dr. ratchet wrench.
- 65mm - 14 flutes - 1 step. 93mm - 15 flutes - 1 step.
- 68mm - 14 flutes - 1 step. 93mm - 36 flutes - 1 step.
- 73mm - 14 flutes - 1 step. 100mm - 15 flutes - 1 step.
- 76mm - 14 flutes - 1 step. 65~67mm - 14 flutes - 2 step.
- 76mm - 30 flutes - 1 step. 74~76mm - 15 flutes - 2 step.
- 80mm - 15 flutes - 1 step. 75~77mm - 15 flutes - 2 step.
- 90mm - 15 flutes - 1 step. 80~82mm - 15 flutes - 2 step.



ST-24007

24PCS - 3/8" & 1/2" DR. OIL FILTER CAP WRENCH SET

- a comprehensive set oil filter wrench for removing both cartridge oil filter cover and oil filter canister.
- work with a 3/8" or 1/2" dr. ratchet wrench.

- | | | |
|----------|----------------------------|-----------------------------|
| 3/8" dr. | 27mm - 6 flutes - 1 step. | 36mm - 6 flutes - 1 step. |
| | 32mm - 6 flutes - 1 step. | 38mm - 6 flutes - 1 setp. |
| 1/2" dr. | 66mm - 6 flutes - 1 step. | 90mm - 15 flutes - 1 step. |
| | 68mm - 14 flutes - 1 step. | 92mm - 10 flutes - 1 step. |
| | 73mm - 14 flutes - 1 step. | 93mm - 15 flutes - 1 step. |
| | 76mm - 8 flutes - 1 step. | 93mm - 45 flutes - 1 step. |
| | 76mm - 12 flutes - 1 step. | 95mm - 15 flutes - 1 step. |
| | 76mm - 14 flutes - 1 step. | 96mm - 18 flutes - 1 step. |
| | 76mm - 30 flutes - 1 step. | 100mm - 15 flutes - 1 step. |
| | 80mm - 15 flutes - 1 step. | 106mm - 15 flutes - 1 step. |
| | 86mm - 16 flutes - 1 step. | 108mm - 15 flutes - 1 step. |



ST-24004

30PCS - 3/8" DR. OIL FILTER CAP WRENCH SET

- a comprehensive set oil filter wrench for removing both cartridge oil filter cover and oil filter canister.
- work with a 3/8" dr. ratchet wrench.

65mm - 14 flutes - 1 step.	93mm - 15 flutes - 1 step.
66mm - 6 flutes - 1 step.	93mm - 36 flutes - 1 step.
68mm - 14 flutes - 1 step.	93mm - 45 flutes - 1 step.
73mm - 14 flutes - 1 step.	95mm - 15 flutes - 1 step.
74mm - 15 flutes - 1 step.	96mm - 18 flutes - 1 step.
76mm - 8 flutes - 1 step.	100mm - 15 flutes - 1 step.
76mm - 14 flutes - 1 step.	106mm - 15 flutes - 1 step.
76mm - 12 flutes - 1 step.	108mm - 15 flutes - 1 step.
76mm - 30 flutes - 1 step.	108mm - 18 flutes - 1 step.
78mm - 15 flutes - 1 step.	65~67mm - 14 flutes - 2 step.
80mm - 15 flutes - 1 step.	74~76mm - 15 flutes - 2 step.
86mm - 16 flutes - 1 step.	75~77mm - 15 flutes - 2 step.
86mm - 18 flutes - 1 step.	80~82mm - 15 flutes - 2 step.
90mm - 15 flutes - 1 step.	2 way oil filter wrench 65~120 mm.
92mm - 10 flutes - 1 step.	adaptor: 1/2" (F) x 3/8" (M).



size	applications
27mm - 6 flutes - 1 step.	Mercedes-Smart-Mercedes C230 (4 cylinder) 2003.
32mm - 6 flutes - 1 step.	GM-Opel-vauxhall-GM-ecotec engine-Mercedes hgv engines-Saab-93 2003-Saturn Ion 4c.
36mm - 6 flutes - 1 step.	Mercedes engines om604 om605 om606-BMW engines m52 m60 m62 m70 m73-Ford-Volvo.
38mm - 6 flutes - 1 setp.	Opel-Vauxhall Vectra 2 liter diesel engines.
65mm - 14 flutes - 1 step.	Fiat-Champ-Hastings-Wix-Napa-Purolator-Daihatsu-Toyota-Nissan.
66mm - 6 flutes - 1 step.	Fiat-punto 12-Renault-clio 1.2express, Kangoo, Rapid, Twingo.
68mm - 14 flutes - 1 step.	Hastings-Mazda-Ford Escort-Capri-Subaru-Fram ph6607-Motorcraft fl816.
73mm - 14 flutes - 1 step.	Toyota-Lexus.
74mm - 15 flutes - 1 step.	MF-Audi-GM-Rover-Chrysler.
76mm - 8 flutes - 1 step.	Fiat (z.b marea)-Lancia (z.b delta).
76mm - 12 flutes - 1 step.	Fiat (z.b ducato, scudo, ulysse)-Renault (megane, laguna, espace III)-Mercedes.
76mm - 14 flutes - 1 step.	Champion-Champ Lee-Purolator-Mopar-VW-Porsche-Mercedes-BMW-Audi-Opel.
76mm - 30 flutes - 1 step.	Motorcraft only-fl400a-Ford.
78mm - 15 flutes - 1 step.	Nissan #15205h8991-Ford-Toyota-Honda-Accord.
80mm - 15 flutes - 1 step.	Hastings-Fram-Purolator-Nissan-Honda-Motorcraft-Mazda-Isuzu-Subaru-Opel-Toyota.
86mm - 16 flutes - 1 step.	Volvo S40, S60, S70, S80.
86mm - 18 flutes - 1 step.	VW Golf (mk III, tdi, passat tdi)-Audi a6 tdi-Renault (clio, rapid 1.9d laguna,) Citroën-Peugeot.
90mm - 15 flutes - 1 step.	Honda Accord-Mitsubishi-Mopar-Isuzu.
92mm - 10 flutes - 1 step.	Cinquecento-Coupe-Croma-Fiat-Panda-Regata-Ritmo Fiat-Seicento-Tempra-Tipo-Lancia.
93mm - 15 flutes - 1 step.	Casite-Champ-Champion-GM-Fram-Hastings-Opel-Mazda-Volvo-Mitsubishi-Purolator-Wix-Nissan-VW-Porsche-Renault-Ford-Honda-Audi.
93mm - 36 flutes - 1 step.	Motorcraft only-fla1a, Fla1b, fl300, fl820/Ford.
93mm - 45 flutes - 1 step.	VW-Audi (tdi 2.4, 2.6, 2.8l.).
95mm - 15 flutes - 1 step.	Toyota #15600-41010-Alfa-GM-Ford-Chrysler.
96mm - 18 flutes - 1 step.	Audi (ar, a6, tdi)-VW (passat 97 tdi)-Renault (laguna 2.2d, safrane 2.2d, espace 2.2d, r19, rapid megane, 1.9/2.1d tdi).
100mm - 15 flutes - 1 step.	Fram-Motorcraft-Wix-Isuzu-Mitsubishi.
106mm - 15 flutes - 1 step.	Fiat (ducato 2.5d. Tdi).
108mm - 15 flutes - 1 step.	Volvo (c70, s70, v70, tdi td) (turbo diesel, 850 tdi diesel).
108mm - 18 flutes - 1 step.	Renault (espace, laguna, master, safrane, trafic 2.4, 2.5, 2.8d, tdi).
65~67mm - 14 flutes - 2 step.	Canada made ph4386, ph4967, ph6017, ph6018-Daihatsu-Toyota.
74~76mm - 15 flutes - 2 step.	Opel-Ford-VW-Mercedes-Fram-AC-Saturn .
75~77mm - 15 flutes - 2 step.	VW-Audi-Casite-GM-AC-Hastings-Wix-Napa-Ford-Isuzu-Mercedes-Opel.
80~82mm - 15 flutes - 2 step.	Wix filters brand for Mazda-Subaru-Toyota-Honda-Acura-Nissan-Napa.

ST-25517

37PCS - SELF-ADJUSTING CLUTCH MASTER TOOL KIT

- 37pc specialist service tool kit for the professional disassembling and assembling of all self-adjusting clutches (SAC).
- necessary for the safe and accurate pre-tightening of SAC pressure plate before their removal and installation.
- prevents plate distortion which may prevent the clutch from disengaging or cause dragging.
- the single piece, six arm plate has been designed for SAC clutch with 6/8 locking hole.
- six arm clamping plate with compression strut and handle.
- clutch resetting tool to reset the adjuster ring, if the existing clutch cover is being reused.
- specialist 6 pcs clutch mandrel set for BMW model, to be used if fitted transit ring prevents conventional alignment.
- face spanner for releasing the locking element on various VAG group model.
- clutch centring tool set ensures the disk is central, relative to the release bearing and pressure plate.
- various size threaded bolts with knurled nuts.



ST-25518

5PCS - CLUTCH ALIGNMENT TOOL SET

- align the clutch disc either relative to the clutch pressure plate or via the pilot bearing relative to the flywheel.
- the self-centering mechanism ensures the tool is being exactly positioned in the clutch disc hub.
- available for clutch hub 15 ~ 28mm (dia.).



ST-25519

13PCS - UNIVERSAL CLUTCH ALIGNMENT TOOL SET

- align the clutch disc either relative to the clutch pressure plate or via the pilot bearing relative to the flywheel.
- the self-centering mechanism ensures the tool is being exactly positioned in the clutch disc hub.
- available for clutch hub 15 ~ 28mm (dia.).
- available for pilot bearing 12, 14, 15, 16, 17, 18, 19mm (dia.).



ST-25520

19PCS - UNIVERSAL CLUTCH ALIGNMENT TOOL SET

- align the clutch disc either relative to the clutch pressure plate or via the pilot bearing relative to the flywheel.
- 1pc - mandrel: 15 ~ 19mm (dia.).
- 1pc - clutch disc aligning adaptor: 19 ~ 30mm (dia.).
- 1pc - mandrel: 20 ~ 26mm (dia.).
- 1pc - spindle: 100mmL.
- 1pc - spindle: 150mmL.
- 1pc - clutch disc aligning adaptor: 26 ~ 35mm (dia.).
- 1pc - clutch plate aligning adaptor: 29 ~ 69mm (dia.).
- 1pc - pilot bearing extension adaptor: 20mmL.
- 1pc - spindle: 55mmL.
- 10pc - pilot bearing adaptor: 10,12,14,15,16,17,19,25,27,30mm (dia.).



ST-25086

9PCS - HARMONIC BALANCE PULLER SET

- the most complete harmonic balancer puller.
- designed to ease the operation of pulling the balancer pulley.
- reduces damage to both pulley and shaft.
- works on most vehicle.
- 1pc - forcing screw 15.5 mm (dia.) - 11T x 140mmL.
- 3pc - screw 3/8" - 24NF x 75mmL.
- 3pc - screw 3/8" - 16NC x 75mmL.
- 1pc - adaptor.
- 1pc - yoke.



ST-24615

29PCS - UNIVERSAL PRESS AND PULL SLEEVE SET

- universal tool set for extracting and drawing in silent bearing, hydraulic bearing, bearing bush, ball bearing, shaft seal, rubber bearing etc.
- fully universal application. ideal for different vehicle, car + HGVs.
- depending on requirement, the particular sleeves can be also be individually reworked (e.g. recess, etc.)
- application also with workshop press + press frame.
- 25pc - press-on sleeves. (inside dia.):
24, 26, 28, 30, 32, 34, 36, 38, 40, 42, 44, 46, 48, 50, 52, 54, 56, 58, 60, 62, 64, 66, 68, 70, 72mm.
- 4pc - pulling spindle + nuts: M10, M12, M14, M16 x 432mmL.



ST-24630

22PCS - UNIVERSAL PRESS AND PULL SET

- universal tool set for extracting and drawing in silent bearing, hydraulic bearing, bearing bush, ball bearing, shaft seal, rubber bearing etc.
- fully universal application. Ideal for different vehicle, car + HGVs.
- depending on requirement, the particular sleeves can be also be individually reworked (e.g. recess, etc.)
- application also with workshop press + press frame.
- 22pc - press-on sleeves. (inside dia.): 34, 36, 38, 40, 42, 44, 46, 48, 50, 52, 54, 56, 58, 60, 62, 64, 66, 68, 70, 72, 75, 80mm. x 5mm (t.).
- 5pc - pulling spindle + nuts: M10, M12, M14, M16, M18.



ST-24651

8PCS - VW BUSH REMOVER / INSTALLER TOOL KIT

- special design for removal and replacement of the silent bloc placed in dirt bracket is easily and safely carried out directly on the vehicle by using the extractor.
- suitable for VW Polo (9N) front-axle bracket wishbon silent blocs.
- applicable:
VW Polo (9N), Seat Ibiza IV, Cordoba (ab bj. 02) Altea, Sköda Fabia, Roomaster, Audi A2.



ST-24652

4PCS - VW AND AUDI BUSH REMOVER / INSTALLER TOOL KIT

- special design for removal and replacement of the silent bloc placed in dirt bracket is easily and safely carried out directly on the vehicle by using the extractor.
- applicable: VAG series.

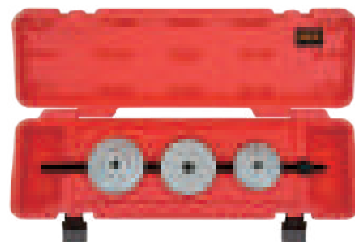

ST-24645

20PCS - SLEEVE SOCKET SET

- this set is designed for removing and installing bushings and bearings.
- suitable for SUV, light trucks and heavy duty vehicles.
- sleeve length: 40mm and 110mm.
- size:

62mm (id) x 70mm (od)	66mm (id) x 74mm (od)
70mm (id) x 78mm (od)	74mm (id) x 82mm (od)
78mm (id) x 86mm (od)	64mm (id) x 72mm (od)
68mm (id) x 76mm (od)	72mm (id) x 80mm (od)
76mm (id) x 84mm (od)	80mm (id) x 88mm (od)



ST-24638

7PCS - STEERING KNUCKLE SPREADER TOOL KIT

- this products is used to spread the steering knuckle to enable the removal and fitting of shock absorbers without the risk of damaging the aluminum or cast iron knuckle.
- the tools is adjustable and suitable for steering knuckles with either a centralized slot or a non centralized slot.
- application: Audi / BMW / Citroën / VW Golf Passat / Ford / Sköda / Seat / Renault / Peugeot / and many Asian vehicles.



ST-23059

C.V. JOINT BOOT CLAMP PLIER

- designed for installing clamp on fuel filter, water pump, CV joint boot and other cooling system hose.
- thickness 3.6 mm and 235 mmL.
- suitable for ear type clamp.

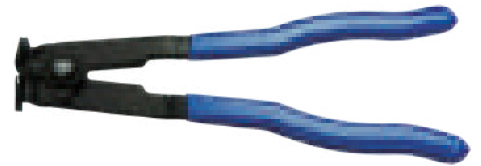

ST-24547

C.V. JOINT BOOT CLAMP PLIER

- using with "torque wrench" or "breaker bar" will be more powerful.
- suitable for easy installation of ear-type clamp on fuel filter, water pump, and others.

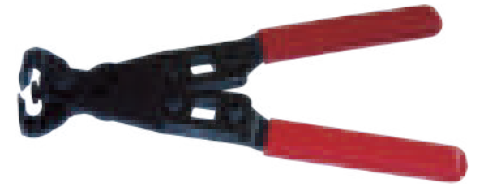

ST-24558

C.V. JOINT BAND TOOL

- easy removal by sliding side-way after winding has been completed.
- using a 1/2" socket wrench or by hand wind the band until sufficient tension is applied.
- suitable for placing band around boot, through nose of tool and through slot in winding body.



ST-24560

C.V. JOINT BAND TOOL W/CUTTER

- easy removal by sliding side-way after winding has been completed.
- using a 1/2" socket wrench or by hand wind the band until sufficient tension is applied.
- suitable for placing band around boot, through nose of tool and through slot in winding body.



ST-24663

CV JOINT PULLER

- for removing the CV joints on front wheel drive cars.
- no need to remove the entire drive axle from the vehicle.
- no need to use a hammer - avoid damaging the drive axle.
- adjusting range length: 135mm.
- mount the nut of the drive shaft maximum 31.5mm (dia.).

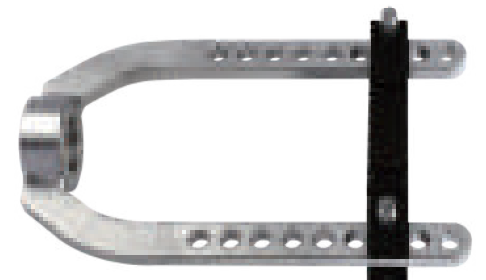

ST-24613

TWO WAY - CV BOOT CLAMP PLIER

- for fitting the high strength stainless steel clamps on modern vehicles where a torque setting is required.
- the two way jaws are designed to work in hard to reach areas.
- using a 3/8" ratchet handle or torque wrench is ideal to provide the drive.
- the plier can adjust the width max. to 42 mm.
- torque requirement 23 ~ 30 Nm.
- application: VW, Audi, Seat, Sköda, Opel / Vauxhall, Ford etc.

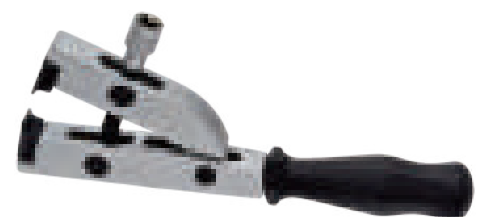

ST-24662

AIR BOOT INSTALATION TOOL

- put the CV boots on the front jaws & ensure the jaws hold CV boots firmly.
- press the pressure bottom, then the front jaws will open to maximum diameter 110mm.
- put the CV boots into the CV joint, then press the release bottom to release the CV boots onto the CV joint.
- CV joint diameter: 25~110mm.
- working pressure: 5~8 kg/m².
- maximum air pressure: 9 kg/m².
- air inlet size: 1/4" BSP.



ST-22011

C-TYPE CLAMP

- C-type clamp with screw fixing for pulling in various direction.
- drop forged steel construction.
- capacity: 5 ton.
- operation: multi-way pull.
- jaw opening: 150 mm.



ST-22012

C-TYPE CLAMP

- C-type clamp with screw fixing for pulling in various direction.
- drop forged steel construction.
- capacity: 5 ton.
- operation: multi-way pull.
- jaw opening: 75 mm.



ST-24528

SMALL MOUTH PULL CLAMP

- small mouth pull clamp car paint spraying equipment and used in automobile maintenance equipment.
- featuring a 360 degree self-tightening pull ring and specially designed non-slip teeth.
- capacity: 5 ton.
- operation: single-way pull.
- bolt size: 16 mm (dia.) x 70 mmL.

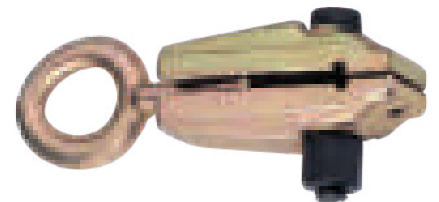

ST-24529

2-WAY SMALL MOUTH PULL CLAMP

- small mouth pull clamp car paint spraying equipment and used in automobile maintenance equipment.
- featuring a 360 degree self-tightening pull ring and specially designed non-slip teeth.
- capacity (straight way): 5 ton.
- capacity (cross way): 2 ton.
- operation: two-way pull.
- bolt size: 16 mm(dia.) x 70 mmL.

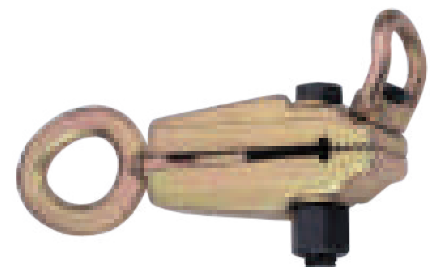

ST-24530

BOX CLAMP

- deep throat fits over or around most vehicle flange.
- featuring a 360 degree self-tightening pull ring and specially designed non-slip teeth.
- capacity: 3 ton.
- operation: single-way pull.
- bolt size: 14 mm(dia.) x 110 mmL.

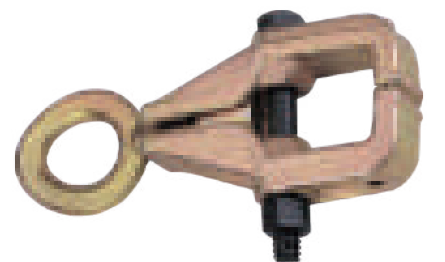

ST-24531

2-WAY BOX CLAMP

- deep throat fits over or around most vehicle flange.
- featuring a 360 degree self-tightening pull ring and specially designed non-slip teeth.
- capacity (straight way): 3 ton.
- capacity (cross way): 2 ton.
- operation: two-way pull.
- bolt size: 14 mm(dia.) x 110 mmL.

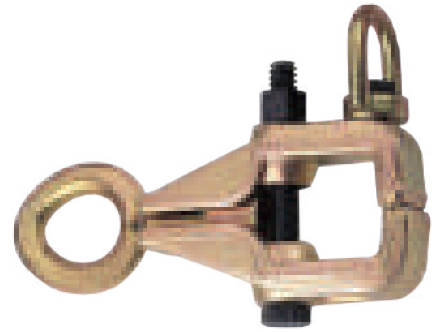

ST-24532

HEAVY-DUTY BOX CLAMP

- deep throat fits over or around most vehicle flange.
- featuring a 360 degree self-tightening pull ring and specially designed non-slip teeth.
- capacity: 5 ton.
- operation: single-way pull.
- bolt size: 20 mm (dia.) x 130 mmL.

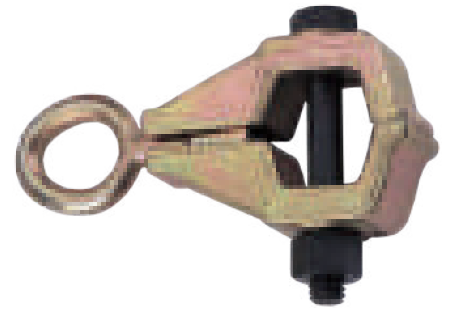

ST-24533

2-WAY MINI CLAMP

- screw clamp with a pulling ring for pulling in two directions.
- due to small size, the clamp can be used in narrow space.
- capacity (straight way): 3 ton.
- capacity (cross way): 2 ton.
- operation: two-way pull.
- bolt size: 14 mm (dia.) x 45 mmL.

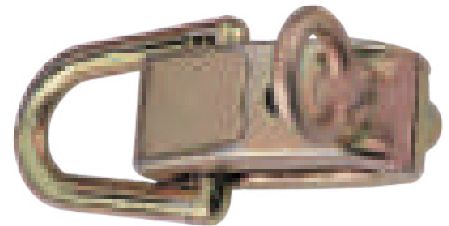

ST-24534

LONG-NOSE CLAMP

- screw clamp with a locking pulling ring for use in narrow and deep place.
- capacity: 2 ton.
- operation: single-way pull.
- bolt size: 14 mm (dia.) x 72 mmL.



ST-24535

SCISSORS CLAMP

- single-way pull operation with serrated jaw for a positive grip.
- clipper design to make operator do not need fixed by screw.
- capacity: 3 ton.
- operation: single way-pull.



ST-24536

CHAIN JOINT

- for use as chain shorter or chain connector.
- contact for two chain is always on a same level, meaning no twisting of chain happens accordingly.
- use with 8 or 10 mm (dia.) chain.
- capacity: 6 ton.



ST-24537

CHAIN JOINT

- for use as chain shorter or chain connector.
- contact for two chain is always on a same level, meaning no twisting of chain happens accordingly.
- use with 8 or 10 mm (dia.) chain.
- capacity: 6 ton.

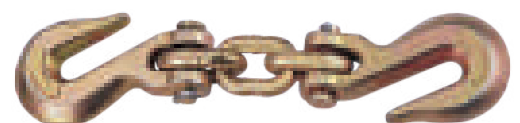

ST-24538

CHAIN JOINT

- for use as chain shorter or chain connector.
- contact for two chain is always on a same level, meaning no twisting of chain happens accordingly.
- use with 8 or 10 mm (dia.) chain.
- capacity: 6 ton.

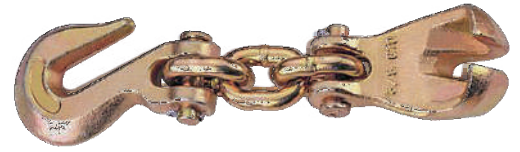

ST-24539

WIDE SERRATE CLAMP

- wide plate makes the clamp to be harder.
- the special puller design used with plate make it hard to be broken.
- serrate width: 120 mm.
- capacity: 5 ton.
- operation: single-way pull.
- bolt size: 14 mm (dia.) x 73 mmL.

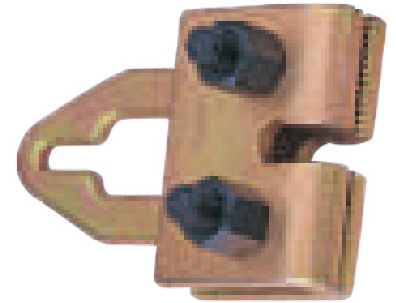

ST-24572

TIGHT OPENING CLAMP

- perfect for small pick-up frame rail.
- redesign and strengthened with new screw-driver mechanism.
- can reach core support and upper sheet metal area.
- new design "tight opening".
- size: W40 x D15 x L165 mm.
- max. opening: 35 mm.
- capacity: 3 ton.

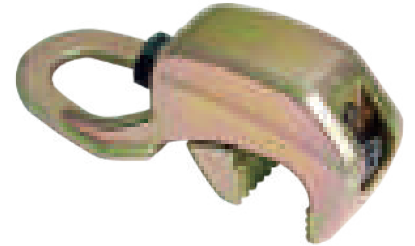

ST-24579

90° CORNER CLAMP

- will be able to get into narrow, confined area.
- cross-hatched teeth is offset to provide a firm grip for straight ahead pulls on right angle corner.
- eliminates the need to use two separate clamps.
- to be used with slide hammer.
- capacity: 2 ton.



ST-24580

90° CORNER CLAMP

- will be able to get into narrow, confined areas.
- cross-hatched teeth is offset to provide a firm grip for straight ahead pulls on right angle corner.
- eliminates the need to use two separate clamps.
- to be used with slide hammer.
- capacity: 2 ton.



ST-24540

BALL JOINT SEPARATOR

- impact free ball joint separation and removal with this effective forged steel device.
- suitable for use on car and light commercial vehicle.
- mini operation space: 6~7 mm.
- jaw opening: 19 mm.



ST-24542

BALL JOINT SEPARATOR

- impact free ball joint separation and removal with this effective forged steel device.
- thin arm designed.
- mini operation space: 6~7 mm.
- jaw opening: 19 mm.



ST-24557

BALL JOINT SEPARATOR

- special design 2-stage operating suits most of car and light truck ball joint insteering and suspension.
- impact free ball joint separation and removal with this effective forged steel device.
- offset lever permits max. jaw opening in 30 mm & 56 mm.
- jaw opening: 22 mm.



ST-24578

BALL JOINT SEPARATOR

- impact free ball joint separation and removal with this effective forged steel device.
- for splitting track rod end, anti-roll bar mountings, ball joint, etc..
- 17 mm / max. jaw opening 58 mm.



ST-24614

5PCS - CHANGEABLE BALL JOINT SEPARATOR SET

- innovative quick-change and simple action for suitable fork.
- enable operator to select correct jaw size without taking entire extractor to the vehicle.
- thrust screw length: 100 mm.
- pivot rod length: 125 mm.
- 5pc - jaw opening 20, 22, 24, 27, 30 mm.



ST-24637

7 TON - HYDRAULIC BALL JOINT PULLER

- unique design and function for dismounting the conic bolt on passenger cars and light commercial vehicles with ease.
- this hydraulic puller is developed for the new front suspensions w/longer conic bolts often fitted in aluminum cones.
- these fittings sit harder & are also more fragile than the older steel versions.
- jaw opening: 25 and 32 mm and fit range: 60 ~ 72 mm.
- capacity force: 7 tons.



ST-24556

BALL JOINT SEPARATOR

- the ball joint separator makes it easy to separate pitman arm, ball joint, tie rod and shock link on a variety of car and truck.
- this tool separates ball joint from steering knuckle.
- tempered drop forged steel, one piece construction for longevity usage.
- strike end of separator with hammer.
- size: 24 mm (fork) x 300 mmL.



ST-24526

5PCS - BALL JOINT SEPARATOR SET

- the ball joint separator makes it easy to separate pitman arm, ball joint tie rod and shock link on a variety of car and truck.
- this tool separates ball joint from steering knuckle.
- tempered drop forged steel, one piece construction for longevity usage.
- strike end of separator with hammer or attach air hammer and apply air pressure to separate.
- 1pc - 17mmW. tie rod attachment. 1pc - 200mmL. striking handle.
- 1pc - 24mmW. ball joint attachment. 1pc - 175mmL. air hammer adaptor.
- 1pc - 28mmW. pitman arm attachment.



ST-24518

39PCS - TURNBUCKLE FOR SHOCK ABSORBER'S TOP LID KIT

- for servicing the shock absorber of spring/strut assembly.
- suitable for a wide variety of vehicle and an essential tool for use with most strut and spring compressor.
- suitable for all kind of vehicle.
- 5pc - yoke: 10.5 - 12.5 - 14.5 - 14.5 - 14 mm.
- 8pc - deep socket: 14 - 16 - 17 - 18 - 19 - 21 - 22 - 24 - 27 mm.
- 9pc - slotted bit: 4-5-2-6-6-3-7-8-9-10-12 mm.
- 2pc - D type bit: D5 - D10. 3pc - slotted bit: 3 - 3.5 - 4.0 mm.
- 4pc - hex nut bit: 8 - 9 - 10 - 11 mm. 1pc - 12 point bit: M12.
- 4pc - hex bit: 5 - 6 - 7 - 8 mm. 2pc - star bit: T50 - T60.

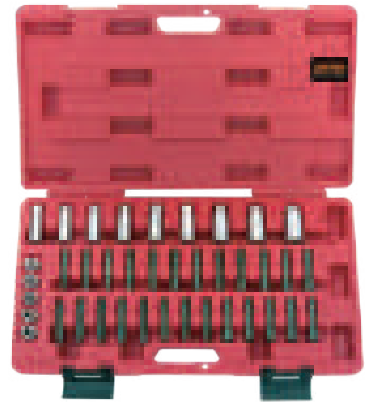

ST-24521

3PCS - REAR AXLE BEARING PULLER SET

- this bearing puller makes it easy to remove semi-floating rear axle bearing.
- choose from three different sizes to fit the main bearing tube (id).
- this bearing puller set works on most of vehicle.
- 1pc - 1" ~ 1-7/8". 1pc - 1-5/16" ~ 2-3/8".
- 1pc - 1-3/8" ~ 2-7/8".

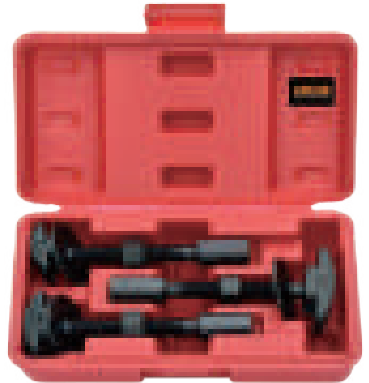

ST-24653

9PCS - TWIST AXLE SPINDLE RETHREADING SET

- special twist shape provides an easier and quicker work. when the axle screw is damaged or with rust.
- this tool set accesses axle threads on spindles of eight popular die sizes for both cleaning and rethreading work.
- this tool set operation with 1/2" dr. ratchet handle or 27mm spanner.
- 1pc - M20 x 1.25 1pc - M20 x 1.50 1pc - M22 x 1.00
- 1pc - M22 x 1.50 1pc - M24 x 1.50 1pc - M24 x 2.00
- 1pc - 13/16" x 20 unef 1pc - 3/4" x 20 unef 1pc - hub/100mmL.



ST-24631

8PCS - STRUT NUT SET

- contains essential for upper piston rod nut on the shock absorber and for spreading the strut clamp in the pivot bearing.
- 1pc - spreading socket: 1/2" dr. x 5.0mm x 60mmL.
- 1pc - spreading socket: 1/2" dr. x 5.5mm x 48mmL.
- 1pc - internal 10.5mm x 22mm hex. drive 3.5mm pin.
- 1pc - internal 12.5mm x 22mm hex. drive 3.5mm pin.
- 1pc - internal 14.5mm x 22mm hex. drive 5.0mm pin.
- 1pc - internal 14.0mm x 22mm hex. drive 3.0mm pin.
- 1pc - internal 15.0mm x external 22mm x 5mm pin.
- 1pc - internal 15.0mm x external 15.5mm x 3mm pin.



ST-24666

SUSPENSION STRUT SUPPORT

- designed to support suspension struts during repair operations.
- to be used in conjunction transmission jacks with a minimum base size of 560mm x 570mm.
- only use with a ram size of 30mm diameter.
- 2pc - jaw opening 60mm and 80mm.



ST-24543

2PCS - COIL SPRING COMPRESSOR SET

- this coil spring clamp tool set is designed to remove coil spring safely in limited space under the wheel arch.
- the jaw design is suitable to wrap coil claw for safety.
- used 1/2" square ratchet handle or 21 mm spanner.
- clamp: 300 mmL.

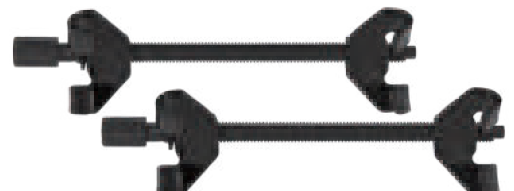

ST-24544

2PCS - COIL SPRING COMPRESSOR SET

- this coil spring clamp tool set is designed to remove coil spring safely in limited space under the wheel arch.
- the jaw design is suitable to wrap coil claw for safety.
- used 1/2" square ratchet handle or 21 mm spanner.
- clamp: 400 mmL.

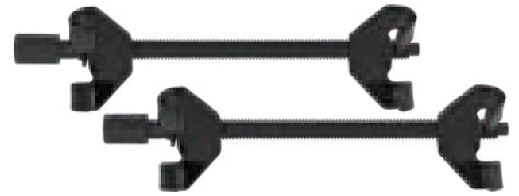

ST-24546

2PCS - COIL SPRING COMPRESSOR SET

- no need extra complicated jaw installation / removal.
- features adjustable safeguard that prevents accidental release of spring under load and also enables the parts of tool used for removing to always operate in parallel.
- hook engage spring can be compressed by turning hex nut.
- use 19 mm hex socket or spanner.
- jaws capacity: 23 mm ~ 280 mm.
- max. capacity: 1200 kg. per pair.

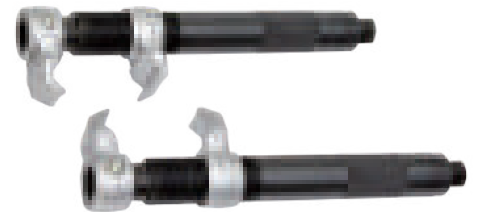

ST-24632

3PCS - COIL SPRING COMPRESSOR WITH SAFETY GUARD SET

- no need extra complicated jaw installation / removal.
- features adjustable safeguard that prevents accidental release of spring under load and also enables the parts of tool used for removing to always operate in parallel.
- hook engage spring can be compressed by turning hex nut.
- use 19 mm hex socket or spanner.
- jaws capacity: 23 mm ~ 280 mm.
- max. capacity: 1200 kg. per pair.



ST-24650

10PCS - MASTER COIL SPRING COMPRESSOR SET

- the 10pcs master coil spring compressor quickly and easily compresses most sizes of macpherson strut springs.
- setup is fast and simple.
- compression is achieved by alternating from one assembly to another.
- every device has heat-treated alloy thrust screws (11 x 300mmL.) with forged hooks.
- can be operated with an air impact wrench.



ST-24507

5PCS - COIL SPRING COMPRESSOR KIT

- advantage: developed automatic 3-point safety.
- supply with two pairs of interchangeable caps provided with a three-hook safety system.
- it offers a quick and easy removal and installation of spring at wishbone and multi-link independent suspension, without dismantling the axle.
- interlock and automatic freewheel at the end of stroke.
- equipped with safety lock for higher security.
- type 116/123/124/126/129/201/202/140 and 4-matic.
- 2pc - plate: 70 and 130mm. (dia.)
- 2pc - plate: 90 and 150mm. (dia.)
- can be operated with an air impact wrench.
- break point: 14,900 kg/f.
- max. load: 5,959 kg/f.
- application: Mercedes Benz / Ford / Saab and more...



ST-24508

7PCS - COIL SPRING COMPRESSOR KIT

- suitable for MacPherson strut coil spring.
- features a yoke extension bracket that also allows using on conical springs.
- equipped with safety lock for higher security.
- 2pc - gold yoke: 80/105 mm. (dia.)
- 2pc - black yoke: 105/140 mm. (dia.)
- 2pc - silver yoke: 145/190 mm. (dia.)
- can be operated with an air impact wrench.
- break point: 4,275 kg/f.
- max. load: 1,710 kg/f.
- application:
Mercedes Benz / BMW / Toyota / Ford / Mitsubishi / Audi / Saab /
VW / Nissan / Honda / Honda Accord /Subaru /Volvo / Opel / Porsche.



ST-24584

MACPHERSON DAMPER SPRING EXTRACTOR SET

- set for compressing MacPherson shock absorber coil spring.
- jaw width is adjustable (100 ~ 250 mm).
- set designed to be used with an air impact wrench.
- equipped with safety lock for higher security.
- break point: 5,800 kg/f.
- max. load: 2,318 kg/f.
- can be operated with an air impact wrench.

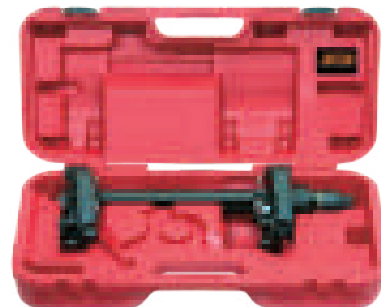

ST-24656

3PCS - INTERNAL COIL SPRING COMPRESSOR KIT

- suitable for coil springs with internal diameter > 75mm and external diameter < 155mm.
- special pins on tool body to mesh with grooves on discs to create a secure connection.
- can be operated with an air impact wrench.
- application:
Audi: A4, A6 / BMW: 3 series E46, X3 E83, X6 E71, E72, Z3 E36.
Citroën: berlingo, C8, dispatch / Fiat: bravo, croma, punto, scudo,
ulyse / Ford: galaxy, maverick, mondeo. / Hyundai: getz, santa fe. /
Mercedes-Benz: A-class W169, W176, B-class W245. / Nissan: cube,
leaf, micra, murano, versa. / Opel: astra G/H/J, corsa B/C, insignia,
zafira A/B. Peugeot: 207, 807, 5008. / Renault: clio, espace, laguna,
thalia. / Tesla: model 3. / Volvo: C70, S80, V60, V70, XC60, XC70.



ST-25075

ALTERNATOR BEARING / GEAR PULLER

- the tightest terminal will be lifted off without damage to battery case or posts, because the sharp jaws are able to engage either below or on the sides of terminals.
- the center screw swivel also makes this puller very effective on alternator bearing.
- working depth: 47 mm.
- jaw thickness: 1.5 mm.
- applicable bearing: 10~30 mm. (dia.)



ST-25042

THIN-TYPE 2-JAW SLIDING LEG BEARING / GEAR PULLER

- thin-type design is suitable for removing bearing in small & narrow space.
- applies even pressure preventing damage to bearing.
- removing bearing or gear from diameter up to 90 mm.
- working depth: 93 mm.
- jaw thickness: 1.5 mm.
- spread: 30 ~ 90 mm.



2-JAW SLIDING LEG BEARING / GEAR PULLER

ST-24634A	spread: 30 ~ 80 mm.
ST-24634B	spread: 30 ~ 120 mm.
ST-24634C	spread: 40 ~ 160 mm.
ST-24634D	spread: 40 ~ 200 mm.

- the claw legs are reversible for internal and external pulling.
- fully adjustable design allows it to fit a variety of application.
- arm and jaw are made forged and machined from quality alloy steel, precision heat treated for max. durability and strength.
- applies even pressure to remove bearing, gear, pulley, and flywheel from shaft without damage.

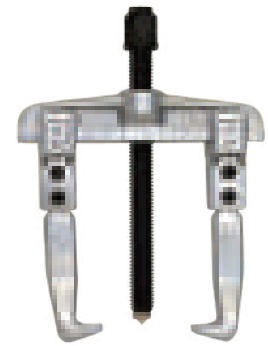
**TWO JAWS REVERSIBLE BEARING / GEAR PULLER**

ST-24601A	spread: 100 mm.	reach: 60 mm.	capacity: 2 ton.
ST-24601B	spread: 150 mm.	reach: 85 mm.	capacity: 5 ton.
ST-24601C	spread: 200 mm.	reach: 85 mm.	capacity: 5 ton.
ST-24601D	spread: 240 mm.	reach: 140 mm.	capacity: 5 ton.

- reversible two-jaw design for internal and external pulling.
- arm and jaw are made forged and machined from quality alloy steel, precision heat treated for max. durability and strength.
- applies even pressure to remove bearing, gear, pulley, and flywheel from shaft without damage.

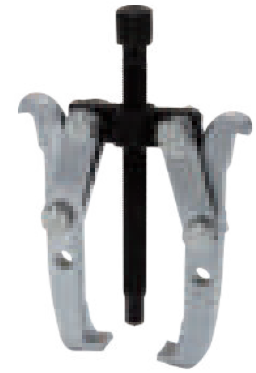
**THREE JAWS REVERSIBLE BEARING / GEAR PULLER**

ST-24602A	spread: 100 mm.	reach: 60 mm.	capacity: 2 ton.
ST-24602B	spread: 150 mm.	reach: 85 mm.	capacity: 5 ton.
ST-24602C	spread: 200 mm.	reach: 85 mm.	capacity: 5 ton.
ST-24602D	spread: 240 mm.	reach: 140 mm.	capacity: 5 ton.

- reversible three-jaw design for internal and external pulling.
- arm and jaw are made forged and machined from quality alloy steel, precision heat treated for max. durability and strength.
- applies even pressure to remove bearing, gear, pulley, and flywheel from shaft without damage.

**ST-24603A****TWO JAWS HYDRAULIC BEARING / GEAR PULLER**

- reversible two-jaw design for internal and external pulling.
- arm and jaw are made forged and machined from quality alloy steel, precision heat treated for max. durability and strength.
- applies even pressure to remove bearing, gear, pulley, and flywheel from shaft without damage.
- jaw grip tighter as more pressure 8 tons is applied.
- reach both: 100 ~ 150 mm.
- max. reach: 125 mm.
- max. spread: 180 mm.

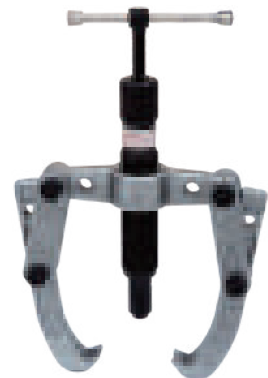
**ST-24604A****THREE JAWS HYDRAULIC BEARING / GEAR PULLER**

- reversible three-jaw design for internal and external pulling.
- arm and jaw are made forged and machined from quality alloy steel, precision heat treated for max. durability and strength.
- applies even pressure to remove bearing, gear, pulley, and flywheel from shaft without damage.
- jaw grip tighter as more pressure 8 tons is applied.
- reach both: 100 ~ 150 mm.
- max. reach: 125 mm.
- max. spread: 180 mm.

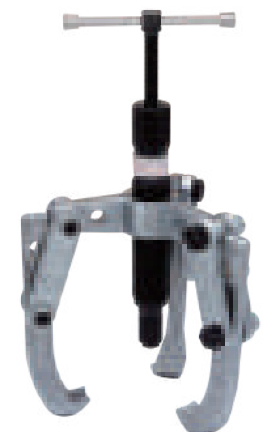

BEARING SEPARATOR

ST-24605A	spread:10~30mm.	bolt:1/4"x20t.x83mmL.	hole size:1/4"x20t.
ST-24605B	spread:30~50mm.	bolt:3/8"x24t.x125mmL.	hole size:3/8"x16t.
ST-24605C	spread:50~75mm.	bolt:1/2"x20t.x135mmL.	hole size:3/8"x16t.
ST-24605D	spread:75~105mm.	bolt:5/8"x18t.x165mmL.	hole size:1/2"x16t.
ST-24605E	spread:105~150mm.	bolt:3/4"x16t.x260mmL.	hole size:5/8"x11t.
ST-24605F	spread:150~200mm.	bolt:1"x12t.x350mmL.	hole size:3/4"x10t.

- remove generator gear, bearing, bearing cone and similar parts where ordinary puller jaw will not reach.
- knife-like edge minimize damage to parts.

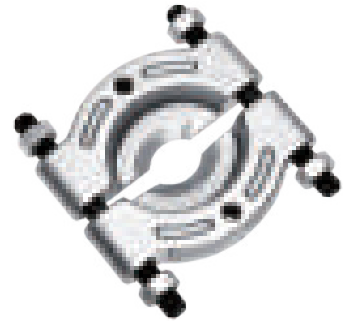
**UNIVERSAL SEAL BEARING AND DRIVER SET**

ST-24617A	jaw range: 9.5 ~ 50 mm.
ST-24617B	jaw range: 18 ~ 90 mm.

- all in one design, eliminating the need for a driver and several different head stepped, adjustable jaw quickly adjust to accommodate bearing race and seal.
- to reduce damage to both race and axle housing.
- can be used on most of vehicle, including motorcycle.
- durable, sturdy aluminium construction with steel capped strike handle.

**ST-24513****5PCS - SLIDING INTERNAL & EXTERNAL BEARING PULLER KIT**

- reversible three-jaw design for inside or outside pull.
- arm and jaw are made forged and machined from quality alloy steel, precision heat treated for max. durability and strength.
- applies even pressure to remove gear, pulley, and flywheel from shaft without damage.
- use the sliding hammer to pull out the bearing.
- internal puller: 15 ~ 30 mm (dia.).
- internal puller: 30 ~ 80 mm (dia.).
- external puller: 15 ~ 80 mm (dia.).

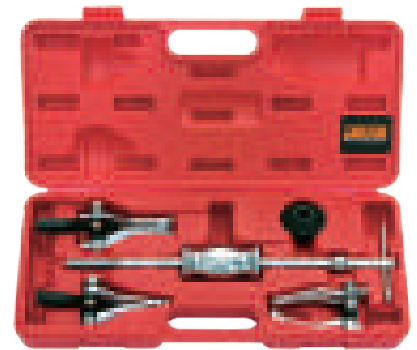
**ST-24506****9PCS - SLIDING INTERNAL BEARING PULLER KIT**

- sliding hammer designed with T-handle, perfect for pulling job requiring an internal pull, such as inner bearing.
- fitting a wide range of application, select the proper clamp by comparing....
- use the sliding hammer to pull out the bearing.
- 8pc - adaptor:
8 ~ 10 mm, 10 ~ 12 mm, 12 ~ 14 mm, 15 ~ 17 mm,
17 ~ 20 mm, 20 ~ 24 mm, 25 ~ 29 mm, 30 ~ 32 mm.

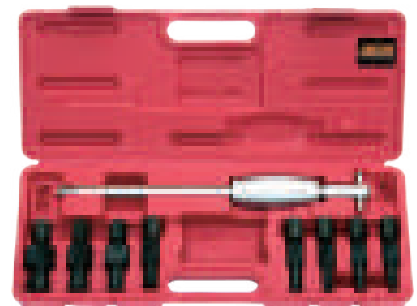
**ST-24514****26PCS - SLIDING HAMMER GEAR/BEARING PULLER KIT**

- it can also be used for removing dent.
- practical in use! Convert into a 2 or 3 jaw internal / external puller.
- gear puller arms can be mounted for inside or outside pulling.
- extracts flange-type rear axles, semi-floating rear axle bearing, balance and other press-on parts also.
- 3pc - adjustable rev. jaw. 3pc - screw and nut. 1pc - 2 way yoke.
- 3pc - adjustable rev. jaw. 1pc - 5 lbs hammer. 1pc - tapping screw.
- 1pc - adjustable rev. nut. 1pc - low axle puller. 1pc - 3 way yoke.
- 1pc - high axle puller. 3pc - adjustable jaw. 1pc - pivot pin.
- 1pc - inside hook jaw. 1pc - forcing screw. 1pc - handle rod.
- 1pc - nut. 1pc - hex Screw. 1pc - attachment.

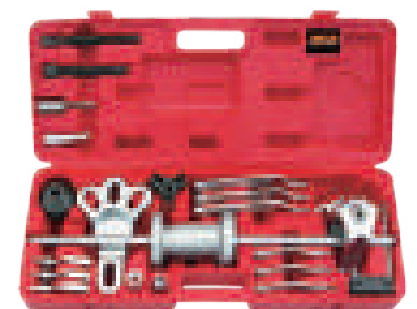

ST-24511

12PCS - TWO SET BEARING SEPARATOR ASSEMBLY KIT

- pull out the bearing with the H-type beam and bolt.
- bearing separator tools are used with bar puller and leg for a wide variety of pulling job.
- 1pc - bearing separator and bolt capacity: 30 ~ 50 mm.
1pc - bearing separator and bolt capacity: 50 ~ 75 mm.
- 4pc - main rod & extension rod. 1pc - beam.
- 4pc - extension rod. 1pc - forcing screw.



ST-24512

8PCS - BEARING SEPARATOR PULLER KIT

- pull out the bearing with the H-type beam and bolt.
- bearing separator tools are used with bar puller & leg for a wide variety of pulling job.
- 1pc - bearing separator and bolt capacity: 75 ~ 105 mm.
- 2pc - main rod (hex bar 19 mm x 10"L. x 1/2"-16T.)
- 2pc - extension rod (hex bar 19 mm x 10"L. x 1/2"-16T.)
- 1pc - beam carbon steel.
- 1pc - forcing screw. 1pc - central bolt.

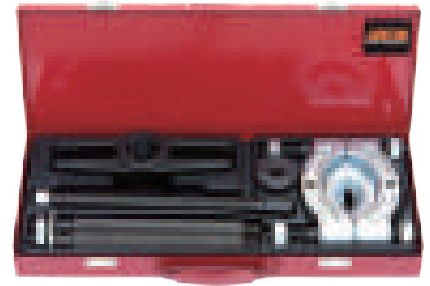

ST-24515

21PCS - HYDRAULIC GEAR / BEARING PULLER KIT

- direct thrust of hydraulic power to release tight bearing, gear, flange, etc.
- for agriculture machine / garage / industry use.
- 1pc - bearing separator and bolt capacity: 75 ~ 105 mm.
- 1pc - central rod. 3pc - 100 mm jaw.
- 2pc - extension rod. 3pc - 150 mm jaw.
- 4pc - main rod. 3pc - 200 mm jaw.
- 1pc - 2 way yoke. 1pc - 3 way yoke.
- 1pc - beam. 1pc - hydraulic ram (10 ton).



ST-24516

17PCS - HYDRAULIC GEAR PULLER KIT

- direct thrust of hydraulic power to release tight bearing, gear, flange, etc.
- for agriculture machine / garage / industry use.
- 1pc - hydraulic ram (10 ton).
- 1pc - ram ext. rod (1.0 mm x 50 mmL.)
- 1pc - sent pop (1.0 mm x 30 mmL.)
- 1pc - combination cross head. 6pc - steel plate.
- 1pc - combination leg. 6pc - screw nut and washer.



ST-25501

1-SPEED 10 TON - HYDRAULIC ALIGNMENT KIT

- 10 ton portable power hydraulic jack kit for lifting, pushing, pulling, straightening, spreading & bending task in auto body and frame repair.
- 1pc - heavy-duty hydraulic hand pump.
- 1pc - jack hose (5 feet). 1pc - 5" extension tube.
- 1pc - 10 ton ram with 6" stroke. 1pc - serrated saddle.
- 1pc - 90 degree "V" base. 1pc - rubber flex head.
- 1pc - 1/2 ton hydraulic spreader ram. 1pc - wedge head.
- 1pc - blow molded case with wheels. 1pc - flat base.
- 1pc - male connector. 1pc - ram toe.
- 1pc - 10" extension tube. 1pc - plunger toe.
- 1pc - 18" extension tube. 1pc - 14-1/2" extension tube.



ST-25508

2-SPEED 10 TON - HYDRAULIC ALIGNMENT KIT

- 10 ton portable power hydraulic jack kit for lifting, pushing, pulling, straightening, spreading & bending task in auto body and frame repair.
- 1pc - heavy-duty hydraulic hand pump.
- 1pc - jack hose (6 feet).
- 1pc - 10 ton ram with 6" stroke.
- 1pc - 90 degree "V" base.
- 1pc - 1/2 ton hydraulic spreader ram.
- 1pc - blow molded case with wheels.
- 1pc - male connector.
- 1pc - 10" extension tube.
- 1pc - 18" extension tube.
- 1pc - 5" extension tube.
- 1pc - serrated saddle.
- 1pc - rubber flex head.
- 1pc - wedge head.
- 1pc - flat base.
- 1pc - ram toe.
- 1pc - plunger toe.
- 1pc - 14-1/2" extension tube.



ST-29015

4PCS - PRY BAR SET

- each bar in this set is built to withstand tough lifting, prying and moving object.
- each bar has a carbon steel square steel shank and a comfortable, ergonomic polypropylene grip to give you the leverage you need for the task at hand.
- 1pc - 6 mm x 200 mmL.
- 1pc - 9 mm x 300 mmL.
- 1pc - 11 mm x 455 mmL.
- 1pc - 11 mm x 600 mmL.



ST-22003

3PCS - ANGLE ADJUSTABLE PRY BAR SET

- these pry bars are ideal for prying seal, axle and drive shaft...
- push design for quick release pry head and easy lock to fix angle.
- when pressure is applied the head will be fixed in place since as push button on the side only allows the head to move when fully pressed in.
- 3pc - angle pry bar: 250 - 300 - 380 mmL.
- max. capacity: 20 kg/m.

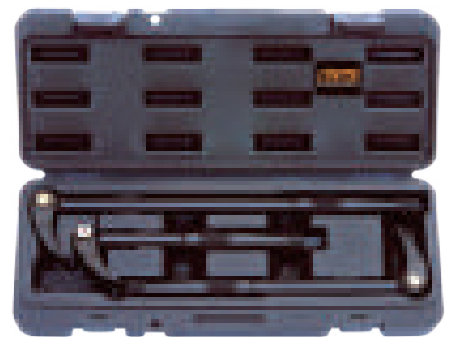

ST-22057

4PCS - HEAVY DUTY PRY BAR SET

- 30° tip angles to adapt to different working situation, offering anti-slip performance.
- great length for achieving a bigger torque and for having accessibility to deep area inside the vehicle.
- durable dual component (PP+TPR) handle for a better grip and protect the end user.
- metal cap to allow the pry bar be hit by a hammer.
- 2pc - W6.0 x 200 mmL. and W9.5 x 300 mmL. bent type x 30°.
- 2pc - W11 x 455 mmL. and W11 x 600 mmL. bent type x 30°.

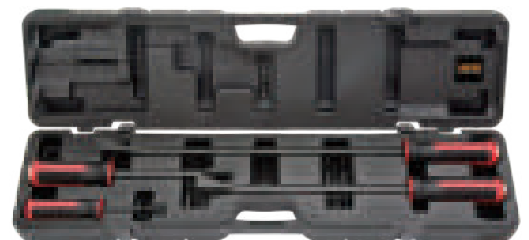

ST-22004

4PCS - JUMBO AND HEAVY DUTY PRY BAR SET

- four different tip angles to adapt to different working situation, offering anti-slip performance.
- great length for achieving a bigger torque and for having accessibility to deep area inside the vehicle.
- durable dual component (PP+TPR) handle for a better grip and protect the end user.
- metal cap to allow the pry bar be hit by a hammer.
- 1pc - W15 x 620 mmL. bent type x 70°.
- 1pc - W35 x 640 mmL. bent type x 90°.
- 1pc - W28 x 920 mmL. bent type x 30°.
- 1pc - W28 x 920 mmL. straight type.

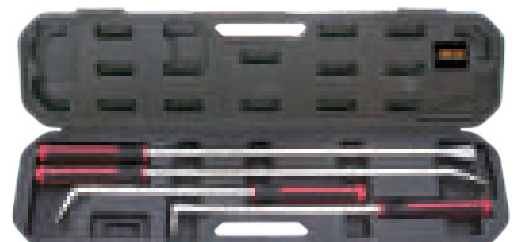

ST-24022

1/4" DR. BRAKE CALIPER REWIND ADAPTOR

- designed with both side for adjustable 2 and 3 pin piston wind-back adaptor.
- can replace the kits containing up to 20 parts.
- rotate brake piston back into the caliper on vehicle with self adjusting parking brake.
- all range is 20 ~ 35 mm.
- fits most of vehicle.
- work with a 1/4" dr. ratchet wrench or breaker bar.

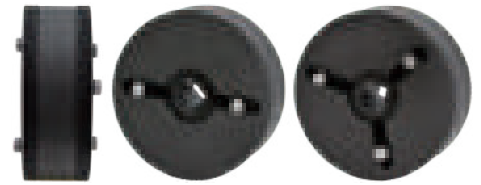

ST-24023

2PCS - 3/8" DR. BRAKE CALIPER REWIND ADAPTOR SET

- designed with 2pcs adjustable 2 and 3 pin piston wind-back adaptor set.
- can replace the kits containing up to 20 parts.
- rotate brake piston back into the caliper on vehicle with self adjusting parking brake.
- all range is 20 ~ 35 mm.
- fits most of vehicle.
- work with a 3/8" dr. ratchet wrench or breaker bar.

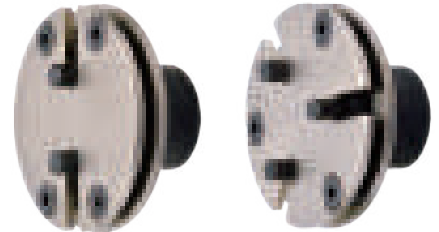

ST-25102

1/2" DR. BRAKE CALIPER PISTON WIND BACK TOOL

- this tool separates piston in the caliper quickly and simply.
- to help pushing the brake caliper piston back squarely with no damage to the piston face.
- spread jaw size: 115 x 50 x 6 mm (t.)
- sliding bolt 100 mmL.
- T-type sliding bolt with 21mm hex head and insert 1/2" dr.



ST-24033

4PCS - BRAKE CALIPER PISTON WIND BACK TOOL KIT

- this tool kit designed for Tesla rear brake caliper piston rewind.
- supplied with both left and right-handle.
- winders enabling the return of the brake piston into the caliper delivering clearance for the new brake pads.
- contents:
 - 1pc - 3/8" dr. rotating caliper (right & left side threaded allow).
 - 1pc - 2 pin piston wind-back adaptor.
 - 1pc - 4 pin piston wind-back adaptor.
 - 1pc - backing pad.
- application: for Tesla only.

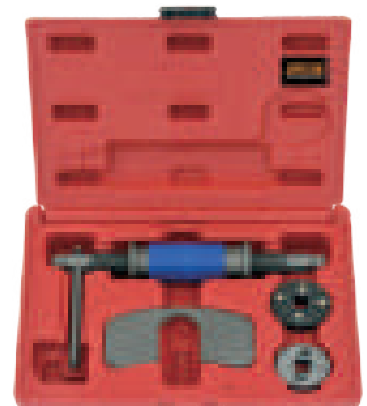

ST-24503

18PCS - BRAKE CALIPER PISTON WIND BACK TOOL KIT

- master set of adaptors for a wide range of vehicle application.
- suitable for push back and wind-back brake piston.
- includes left and right handed thrust bolt assembly.
- precision made adaptor plate with thrust bolt assembly and reaction plate.
- to prevent the damage on piston and seal.
- application:
 - Alfa Romeo / Audi / BMW / Citroën / Ford / Honda / Jaguar / Mazda / Mercedes / Mitsubishi / Nissan / Peugeot / Fiat / Renault / Rover / Saab / Seat / Skoda / Subaru / Toyota / Opel / Vauxhall / VW.



ST-24583

21PCS - BRAKE CALIPER PISTON WIND BACK TOOL KIT

- master set of adaptors for a wide range of vehicle application.
- suitable for push back and wind-back brake piston.
- includes left and right handed thrust bolt assembly.
- precision made adaptor plate with thrust bolt assembly and reaction plate.
- to prevent the damage on piston and seal.
- application:
Alfa Romeo / Audi / BMW / Citroën / Fiat / Mazda / Ford / Mitsubishi / Honda / Jaguar / Mercedes / Nissan / Rover / Peugeot / Renault / Saab / Seat / Sköda / Subaru / Toyota / Vauxhall / Opel / VW / Audi A8, S9.



ST-24569

37PCS - BRAKE CALIPER PISTON WIND BACK TOOL KIT

- master set of adaptors for a wide range of vehicle application.
- suitable for push back and wind-back brake piston.
- includes left and right handed thrust bolt assembly.
- precision made adaptor plate with thrust bolt assembly and reaction plate.
- to prevent the damage on piston and seal.
- application:
Audi/Fiat/Alfa Romeo/Ford/Isuzu/Honda/Jaguar/Mitsubishi/BMW/M Benz/ Nissan/Rover/Toyota/Volvo/VW/Mazda/Saab/GM/Subaru/Peugeot/ Citroën/Renault/Seat/Lancia/Mini Cooper/Proton/Mazda/Laguna.



ST-24621

44PCS - BRAKE CALIPER PISTON WIND BACK TOOL KIT

- master set of adaptors for a wide range of vehicle application.
- suitable for push back and wind-back brake piston.
- includes left and right handed thrust bolt assembly.
- precision made adaptor plate with thrust bolt assembly and reaction plate.
- to prevent the damage on piston and seal.
- application:
Citroën/Jaguar S type/BMW mini/Citroën XM/Alfa Romeo/Audi/Austin/Ford/ BMW/Jaguar/M Benz/Mitsubishi/Nissan/Rover/Toyota/Subaru/Honda/Saab 9000/VW golf, passat/GM/Renault/Opel/Peugeot/Lancia/Proton/Lincoln...



ST-24504

16PCS - AIR POWERED BRAKE CALIPER PISTON WIND BACK TOOL KIT

- air operated wind-back tool is suitable for left or right hand wind-back operation.
- master set of adaptors suit a wide range of vehicle application.
- suitable for push-back & wind-back brake piston.
- interchangeable adaptor plate with thrust bolt assembly & reaction plate.
- left or right wind-back operation.
- application:
Alfa Romeo / Audi / BMW / Citroën / Fiat / Ford / VW / Mitsubishi / Honda / Jaguar / M Benz / Mazda / Nissan / Peugeot / Rover / Saab / Seat / Opel / Subaru / Toyota / VW / Volvo.



ST-24582

22PCS - AIR POWERED BRAKE CALIPER PISTON WIND BACK TOOL KIT

- air operated wind-back tool is suitable for left or right hand wind-back operations.
- master set of adaptors suit a wide range of vehicle applications.
- suitable for push-back & wind-back brake pistons.
- interchangeable adaptor plates with thrust bolt assembly & reaction plate.
- lift or right wind-back operation.
- application:
Alfa Romeo/Audi/BMW/Citroën/Fiat/Ford/Honda/Mitsubishi/Jaguar/ Mazda/Mercedes/Nissan/VW/Peugeot/GM/Rover/Saab/Seat/Opel/ Subaru/Toyota/ VW/Volvo/Isuzu/Renault/Lancia/Iveco Daily/Mini.



ST-29008

BRAKE CYLINDER HONE

- collar prevents stone breakage.
- sleeve makes insertion in cylinder ease and protects stones when not in use.
- flexible shaft with an adjustable honing tension.
- capacity: 19 mm ~ 63 mm (dia.).



ST-24581

REAR PARKING BRAKE SPRING TOOL

- this application requires a smaller brake spring tool with more reach.
- special tip is designed to engage the shoe hold down spring cup on TOYOTA vehicle.
- application:
2000~current Toyota Camry / Tacoma / FJ Cruiser / Tundra / Land Cruiser.



ST-24597

BRAKE SPRING WASHER TOOL

- the little spring & cup washer that keep your brake shoes flat against the back plate regularly fly across the garage when being installed or removed with plier.
- designed with double-end tool makes it a simple matter of push and turn to either remove or fit them and keeps everything in place.
- fit size: 16 ~ 17 mm and 17 ~ 22 mm (dia.).



ST-24598

BRAKE RETAINER SPRING TOOL

- the brake spring washer tool removes and installs both large and small brake spring washer.
- fit size: 16 ~ 22 mm (dia.).



ST-24599

BRAKE SHOE HOLD-DOWN CLIP TOOL

- remove & install the brake clip & nail on brake shoes in seconds.
- set tool head in the brake clip groove.
- push tool to depress brake clip, turn hand 1/4 turn to disengage clip from nail than reverse to install.



ST-24618

DRUM BRAKE SPRING SERVICE PLIER

- designed to aid installation and removal of brake shoes retaining spring washer found in brake assembly.
- spring loaded; offset jaws enable easy access to the spring washer located behind wheel hub.
- suitable for cars and light commercial vehicle.
- length: 180.5 mm.
- max. angle: 50 degree.



ST-24667

UNIVERSAL PEDAL DEPRESSOR

- depressor and holds all kind of car and truck's brake and clutch pedal.
- the stepless, extendable design allow the mechanic to adjust the tool in any preferred position.
- the coated U-shaped steel plate can be placed on the steering wheel or the seat firmly.
- this depressor can be extended from 630 to 950mmL.



ST-24639

UNIVERSAL BRAKE BLEEDING ADAPTOR

- universal brake filling adaptor with adjustable wings to fit various master cylinder filler neck sizes & a conical rubber to fit various opening sizes.
- european type air inlet plug is compatible with major brake filling machines on the market as well as ST-24640.
- holds pressure up to 3.5 bar.



ST-24640

4PCS - BRAKE BLEEDING ADAPTOR SET

- adaptor kit for fitting brake master cylinder caps to introduce brake fluid connected from brake service machines.
- includes 3 specific adaptor and 1 universal adaptor with a fastening chain.
- E20 adaptor with a 90° extension hose and free rotation feature provides unrestricted access to limited spaces.
- E20 extension hose made of brake fluid resistant materials.
- application:
 - 78.1mm (dia.): universal application with chain fastener.
 - 33mm (dia.): Chrysler, Ford explorer, Hyundai, Mazda 6, Subaru.
 - 79.5mm (dia.) x P3.0: Mitsubishi, Nissan, Subrau, Suzuki, Volvo S40 and V40.
 - 46.5mm (dia.) x P3.5: European vehicles, Ford, Fiesta and Focus, Galaxy s-max.



ST-24647

6PCS - BRAKE BLEEDING ADAPTOR SET - electric vehicles

- designed for applications on master cylinder reservoirs from 2001 to 2020. covers at least 90% of all the common vehicles on the market.
- adaptors with standard european air plug type. suitable for pressure bleeding tools or machines.
- most adaptor have a swivel 90° fitting to tackle limited space problems.
- application:
 - Audi e-Tron, BMW i3, BMW i8, Chevrolet Bolt EV, Hyundai Kona Electric, Hyundai Ioniq Electric, Kia Niro EV, Mitsubishi Outlander PHEV. Nissan e-NV200, Nissan Leaf, Renault Zoe, Toyota Prius PHEV, Volvo XC40 / XC60 Hybrid, VW e-Golf.



ST-24657

13PCS - BRAKE BLEEDING ADAPTOR SET

- this new kit contains master cylinder adaptor which cover domestic vehicles.
- it contains many universal adaptors and manufacturer specific caps. an adaptor is also available to use with traditional pressure bleeders.
- adaptors fit 90% of current master cylinder reservoirs.
- suitable for use with most pressure brake bleeders. includes european cap adaptor, multi vehicle caps, american adaptor (GM), BMW, Audi, Mazda, Honda.



ST-24641

2PCS - BRAKE PRESSURE BLEEDING SET

- one-person operation on brake bleeding by pressurizing the brake system from master cylinder.
- efficient in pushing out debris from brake system.
- quart tank with a safety pressure relief valve.
- includes a standard european adaptor with a swivel 90° fitting to tackle limited space.
- one-way valve is fitted in the hose end connector to prevent unsafe brake fluid spills after disconnecting the hose from master cylinder.
- capacity: 3-liter.



ST-23040

NON-POWER BRAKE OIL RECEIVER

- simple way to release the remained brake oil.
- silicone hose with hydraulic brake oil check valve.
- universal rubber adaptor can fit most vehicle brake oil bleeder fitting.
- capacity: 1-liter.

ST-23041

BRAKE OIL BLEEDER

- easy carry and operation with light weight.
- topping up the brake reservoir and bleeding brakes at the same time.
- offset fluid bottle with adjustable neck for easy engine access.
- maintaining fluid level while operation can reduce risk of accidental spillage during topping up.
- airtight fixtures ensures fluid can be stored safely without risk of contamination display packed.
- capacity: 1-liter.

ST-25103

BASIC BRAKE OIL EXTRACTOR

- economical - fast and easy, reduce working time.
- versatile - handle most of standard and ABS brake system.
- clean - collects old brake fluid without spillage.
- quiet - integrated silencer for a quieter working environment.
- silicone suction assembly with universal rubber fitting.
- capacity: 2-liter.

ST-25104

VACUUM BRAKE FLUID BLEEDER

- air vacuum brake bleeder.
- use standard workshop air supply.
- removing fluid via bleeder is suitable for most of fluid replacement.
- capacity: 1-liter.

ST-25113

VACUUM BRAKE FLUID BLEEDER

- air vacuum brake bleeder.
- uses standard workshop air supply.
- removes fluid via bleed nipples to allow bleeding or entire fluid replacement.
- capacity: 6-liter.

ST-25114

MANUAL BRAKE FLUID BLEEDER

- standard with adaptor for european cars.
- optional universal adaptor.
- capacity: 4.0-liter.



ST-25115

BRAKE FLUID RECEIVING BOTTLE

- brake nipple to fit on all bleeding point.
- check valve design to prevent air into the system.
- there are magnets on the bottom.
- capacity: 0.6-liter.



ST-23016

VACUUM PUMP AND BRAKE BLEEDING KIT

- this kit includes the vacuum complete fitting accessories for vacuum testing and brake bleeding.
- the vacuum pump is field repairable, replace wrong O-ring, seal and valve with the vacuum pump repair kit.
- attach many kinds of joint to fit most kind of vehicles.
- has the switch to control two kinds of pressure condition.
- pressure range: positive pressure 0 ~ 60 psi.



ST-23048

VACUUM PUMP AND BRAKE BLEEDING KIT

- a multi-function kit that provides a vacuum pump for vacuum-related tests and brake bleeding.
- the vacuum-operated system includes intake manifold, auto. Transmission, fuel control, exhaust gas recirculation (EGR), air conditioning and heating systems.
- bleeding air in the brake system with this kit can be operated individually, without needing another person depressing the brake pedal while bleeding the air.
- it is suitable for ABS, conventional brake system and power brake system.
- provided with a pack of adaptors for different brake bleeder valves.



ST-24642

VACUUM PUMP AND BRAKE BLEEDING KIT

- a multi-function kit that provides a vacuum pump for vacuum-related tests and brake bleeding.
- the vacuum-operated system includes intake manifold, auto. Transmission, fuel control, exhaust gas recirculation (EGR), air conditioning and heating systems.
- bleeding air in the brake system with this kit can be operated individually, without needing another person depressing the brake pedal while bleeding the air.
- it is suitable for ABS, conventional brake system and power brake system.
- provided with a pack of adaptors for different brake bleeder valves.



ST-24619

4PCS - BRAKE CALIPER SOCKET SET

- special socket to repair C.V. brake caliper.
- for SAF, NFZ and Knorr brake caliper system.
- size: H8, H10, S8, 11PT.
- drive SW12 12mm hex drive.
- magnetic to hold socket.



ST-24628

BRAKE LINING THICKNESS GAUGE

- to offer the accurate measurement of how much brake lining is left without guess work.
- inspection: red: 2,3 mm. yellow: 4,5,6 mm. green: 8,10,12 mm.



ST-24024

5PCS - SLOGGING WRENCH SET FOR BRAKE CALIPER SCREW

- use of the wrench for assembly and disassembly of the brake caliper screw connection on commercial vehicle.
- correct tightening of screw with torque wrench in accordance with the manufacturer's specification.
- wrench flat with lasered formula for calculating the correct effective length.
- (ST-24024-1) 1pc - torx E18 for MAN TGL/TGM.
- (ST-24024-2) 1pc - torx E20 for MAN TGL/TGM.
- (ST-24024-3) 1pc - torx E24 for MAN TGA/TGS/TGX.
- (ST-24024-4) 1pc - 12-point M24 for SAF.
- (ST-24024-5) 1pc - 12-point M26 for DAF XF/XF95/XF105/XF106.

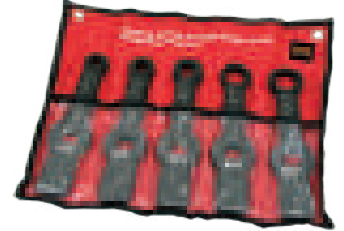

ST-24034

SUPER SCRAPER

- this tool designed to scrape off rusts on brake calipers, old silicone on oil pans and carbon buildup on exhaust manifolds.
- finely ground carbide double edges scrape residues off without leaving a damage on the surface and cleans everything easily.
- premium tungsten carbide tip remains sharp for an extended period of time.
- ergonomic handle design offers comfortable grip.
- 32mm wide blade to clean up more efficiently.
- tool total length is 210mmL.



ST-25108

BRAKE FLUID TESTER

- suitable for DOT4 brake fluid.
- the brake fluid tester is suitable for determining brake fluid quality.
- recommended testing fluid temperature: 25 ~ 32°C.
- working ambient temperature: 0 ~ 50°C.
- height above sea level: 2000 M.
- humidity: 0~85%.



ST-25109

BRAKE FLUID TESTER

- suitable for DOT3, DOT4 & DOT5 brake fluid.
- the brake fluid tester is suitable for determining brake fluid quality.
- recommended testing fluid temperature: 25 ~ 32°C.
- working ambient temperature: 0 ~ 50°C.
- height above sea level: 2000M.
- humidity: 0~85%.



ST-25110

BRAKE FLUID TESTER

- suitable for DOT4 brake fluid.
- press switch to turn on - green LED illuminates to indicate battery OK.
- immerse probe of the tester into brake fluid.

green LED = brake fluid H₂O < 1.5%yellow LED = brake fluid H₂O < 1.5~3%red LED = brake fluid H₂O > 3%

brake fluid OK / battery OK.

low percentage of water, change again within 6 months.

change brake fluid.

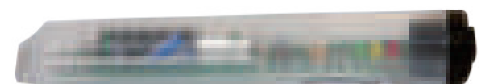

ST-24606

8PCS - WHEEL STUD CLEANING TOOL KIT

- faster and easier to clean studs.
- only need one tool to fit different sizes of brush.
- quick change brush in 5 seconds.
- this kit is designed to used with a cordless drill or wrench.
- come with a 1/2" drive adaptor and six brushes.
- brush size: 12, 13, 14, 16, 22, 28 mm (id).



ST-24626

13PCS - WHEEL HUB CLEANER SET

- this tool attacks the rust on lug stud and rotor on the hub.
- assembly faster and easier .
- usable on most of vehicle with either front or rear disc brake.
- shank: hex. 8 mm x 30 mmL.
- nylon stripping wheel size: 15mm (id) x 39mm (od) x 17mm (t.).
- including 10pcs of stripping wheel.



ST-24627

4PCS - WHEEL HUB CLEANER SET

- designed working with 1/2" dr. cordless or air impact wrench.
- for cleaning the wheel centering device as well as the attachment area between the wheel and hub.
- corrosion between the rim and the wheel hub is removed and torque values can no longer be distorted.
- maximum 1,500 rpm.
- nylon stripping wheel size: 90mm (id) x 150mm (od) x 13mm (t.).
- including 3pcs of stripping wheel.



ST-24616

SUPPORTING DEVICE FOR CONTROL ARMS

- this tool is designed to be used in conjunction with a standard transmission jack.
- the device is fitted to the top of the transmission jack replacing the standard saddle for the support of vehicle wheel hub.
- the device is used by location to the vehicle hub using the vehicle's wheel nuts/studs allowing accurate raising and lowering of the control arms/axles to the correct position for fixture/adjustment.
- this tool is an indispensable assistance when removing or installing a suspension unit and helps to make a difficult job easy.

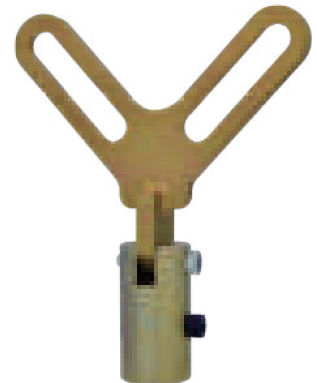

ST-24633

WHEEL HUB BUSTER

- an essential time saving tool to remove frozen/corroded hub assembly instantly without damaging the axle.
- universal mount fits all axle bolted hubs (5, 6, and 8 lug hubs).
- mount to (2) studs using supplied flange nut.
- use with 2 kg hammer to knock frozen hub out of axle.
- reinforce striking plate for longevity.



ST-24559

6PCS - UNIVERSAL HUB PULLER SET

- removes wheel hubs mounted on tapered axles and press-fit rear drum brakes.
- constructed of heat-treated forged alloy steel and fine-threaded 28mm hex. drive center bolt.
- maximum reach is 200mm bolt circle.
- has readily adjustable sliding arms to pull wheel hubs quickly and easily.
- provides a straight pull - will not distort wheel lugs.
- striking wrench and puller screw included.



ST-24636

10PCS - TWO WAY UNIVERSAL HUB PULLER SET

- this is a 5 leg puller with slide through center bolt forcing screw for impact action plus a 10 ton hydraulic ram with extension pieces.
- removes wheel hubs mounted on tapered axles and press-fit rear drum brakes.
- constructed of heat-treated forged alloy steel and fine-threaded 28mm hex. drive center bolt.
- maximum reach is 200mm bolt circle.
- has readily adjustable sliding arms to pull wheel hubs quickly and easily.
- provides a straight pull - will not distort wheel lugs.
- striking wrench and puller screw included.

ST-24607

10PCS - HYDRAULIC CYLINDER OPERATION REPAIR TOOL KIT

- two specially designed adaptor, accurate and safe guidance of hydraulic cylinder and the clamping nut fixed on the wheel hub bearing tool set center.
- the kit is designed to press out of the universal joint drive shaft and drive shaft.
- new design of the disk will be able to operate ST-24610 and ST-24612 series by hydraulic.

ST-24608

18PCS - WHEEL HUB PULLER KIT

- this kit with the slide hammer can remove wheel hub, half share, brake drum, drive shaft directly in the car.
- a mechanical spindle can press out drive shaft.
- bolt size: M12 x 1.5 t. / M14 x 1.5 t.
- spindle standard: 2-1/4" x 14 uns / range: 90~130 mm. / 160 mm (o.d.)
- suitable for VW, Audi, Alfa Romeo, Ford, Citroën, BMW, Mazda, Fiat, M-benz, Seat, Opel, Peugeot, Renault, Sköda, Porsche, etc.

ST-24609

25PCS - WHEEL BEARING PULLER KIT

- this tool kit is for the precise, quick & professional removal and replacement of wheel bearing.
- the design prevent damage to the new wheel bearing because the press pieces enable safe and accurate centering and alignment when changing wheel bearing.
- for wheel bearing diameter 60 ~ 85 mm.
- suitable for VW, Audi, Seat, Opel, BMW, etc.

ST-24610

18PCS - WHEEL HUB / BEARING REPAIR TOOL KIT

- for removing and installing the wheel hub or wheel bearing of built-in parts on car.
- the design prevent damage to the new wheel bearing because it provides safe and accurate centering and alignment when changing wheel bearing.
- for wheel bearing diameter 78 mm.
- suitable:
Ford Focus 2 (2004-2007) / Focus 2.5RS (2007) / Focus 2.5RS 500 (2007) / Mondeo 4 (2007) / C-max (2003) / Volvo C30 (2006) / C70 2 Cabriolet (2006) / S40 (2004) / V50 (2004) / Mazda M3 (bk) 1.4, 1.6, 1.6D turbo (2003).

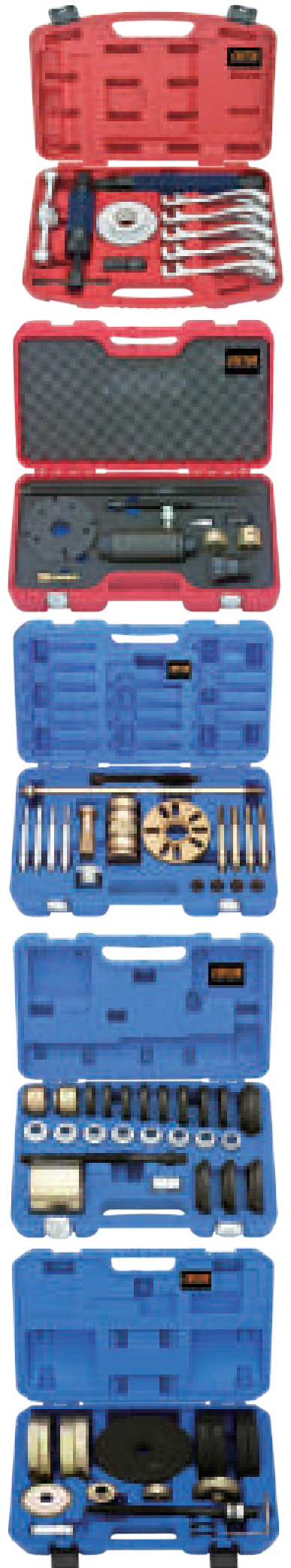

ST-24611

18PCS - WHEEL HUB / BEARING REPAIR TOOL KIT

- for removing and installing the wheel hub or wheel bearing of built-in parts on car.
- the design prevent damage to the new wheel bearing because it provides safe and accurate centering and alignment when changing wheel bearing.
- for wheel bearing diameter: 85 mm.
- suitable: VW T5 / transporter / multivan touareg.



ST-24612

41PCS - WHEEL HUB / BEARING REPAIR TOOL KIT

- for removing and installing the wheel hub or wheel bearing of built-in parts on car.
- the design prevent damage to the new wheel bearing because it provides safe and accurate centering and alignment when changing wheel bearing.
- for wheel bearing diameter: 62 mm. / 72 mm. / 85 mm.
- suitable:
Audi A2 (1995-05) / VW lupo (1995-05) / Polo (2000-02) / Fox (2005) T5, transporter / Multivan / Touareg / Seat-rosa (1995-05) / Cordoba (1995-05) / Ibiza (1995-05) / Skoda-Fabia / roomster.



ST-24624

13PCS - WHEEL HUB / BEARING REPAIR TOOL KIT

- for removing and installing the wheel hub or wheel bearing of built-in parts on car.
- the design prevent damage to the new wheel bearing because it provides safe and accurate centering and alignment when changing wheel bearing.
- for wheel bearing diameter: 90 mm.
- suitable:
Audi A4/S4, A6/S6, A8/S8/R8



ST-32007

WHEEL NUT CAP REMOVER PLIER

- removes chrome-plated lug nut caps found on many heavy-duty truck.
- most ruggedly built remover available can with stand the extra force applied.
- during cap removal won't bend or break under pressure.



ST-32008

WHEEL NUT CAP REMOVER PLIER

- solid, hard to reach cap of wheel bolts / nut pull off without damage and fast.
- enables the damage-free removal of wheel nut cap on aluminum rim.
- application: Audi / VW / Opel etc.

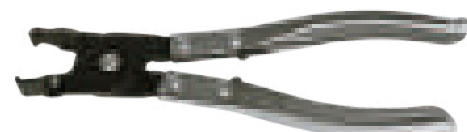

ST-32003

1/2" DR. LOCKING WHEEL SOCKET - Mercedes Benz

- this socket enables servicing of customer vehicle, even lost the key.
- material: Cr-Mo steel and black oxide finish.
- size: 17 mm x 85 mmL.
- suitable for installing and removing locks of "Mercedes Benz" only.

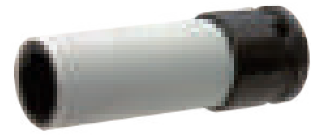
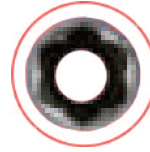

ST-32030

3PCS - 1/2" DR. LOCKING WHEEL SOCKET SET

- this socket enables servicing of customer vehicle, even lost the key.
- material: Cr-Mo steel and black oxide finish.
- thin wall for aluminum wheel use.
- size: 17, 19, 21 mm x 85 mmL.
- available for Mercedes Benz, Kia, Hyundai.

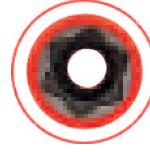

ST-32031

3PCS - 1/2" DR. SPLINE LOCKING WHEEL SOCKET SET

- this socket enables servicing of customer vehicle, even lost the key.
- material: Cr-Mo steel and black oxide finish.
- thin wall for aluminum wheel use.
- size: 17, 19, 21 mm x 85 mmL.
- available for vehicles: VW, Audi and Skoda.

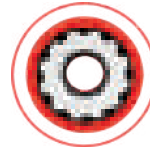

ST-32015

30PCS - LOCKING WHEEL NUT KEY SET - MERCEDES BENZ

- this socket enables servicing of customer vehicle, even lost the key.
- material: Cr-Mo steel and chrome finish.
- application for installing and removing lock of "Mercedes Benz" only.
- 30pc - wheel lock adaptor:

#301	#302	#303	#304	#305	#306
#307	#308	#309	#310	#311	#312
#313	#314	#315	#316	#317	#318
#319	#320	#321	#322	#323	#324
#325	#326	#327	#328	#329	#330



ST-32025

12PCS - LOCKING WHEEL NUT KEY SET - MERCEDES BENZ

- this socket enables you to permit servicing of customer vehicles, even lost the key.
 - material: Cr-Mo steel and chrome finish.
 - applications for Mercedes Benz:
A class, B class, C class, GLK class, CLC class, CLS class, CLK class, E class, SL class, SLK class, M class, C300, C250, C350, E320, 204, 211, 212, R class.
 - 10pc - wheel nut socket:
- | | | | | |
|-----------|-----------|-----------|-----------|-----------|
| #301 (5A) | #303 (5C) | #304 (5D) | #306 (5F) | #307 (5G) |
| #312 (5N) | #313 (5P) | #319 (5X) | #331 (5E) | #332 (5L) |



ST-32027

35PCS - LOCKING WHEEL NUT KEY SET - MERCEDES BENZ

- this socket enables you to permit servicing of customer vehicles, even lost the key.
- material: Cr-Mo steel and chrome finish.
- application for Mercedes Benz:
A class, B class, C class, GLK class, CLC class, CLS class, CLK class, E class, SL class, SLK class, M class, C300, C250, C350, E320, 204, 211, 212, R class.



ST-32009

20PCS - LOCKING WHEEL NUT KEY SET - BMW

- this socket enables you to permit servicing of customer vehicle, even lost the key.
- material: Cr-Mo steel and chrome finish.
- application for installing and removing lock of "BMW" only.
- 20pc - wheel lock adaptor:

#41	#42	#43	#44	#45	#46	#47	#48	#49
#50	#51	#52	#53	#54	#55	#56	#57	#58
#59	#60							



ST-32010

10PCS - LOCKING WHEEL NUT KEY SET - BMW

- this socket enables you to permit servicing of customer vehicles, even lost the key.
- material: Cr-Mo steel and chrome finish.
- application for installing and removing locks of "BMW" only.
- 10pc - wheel lock adaptor:

30/13PT	31/15PT	32/16PT	33/17PT	34/18PT
35/19PT	36/20PT	37/21PT	38/22PT	40/23PT

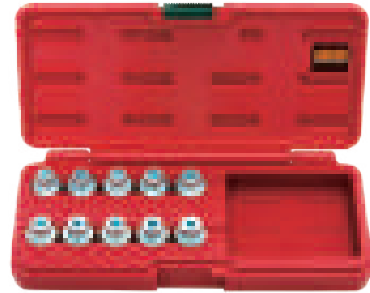

ST-32012

21PCS - LOCKING WHEEL NUT KEY SET - BMW

- this socket enables you to permit servicing of customer vehicles, even lost the key.
- material: Cr-Mo steel and chrome finish.
- application for installing and removing locks of "BMW" only.
- 1pc - 1/2" dr. wheel lock socket 17 mm x 85 mmL.
- 20pc - wheel lock adaptor:

11/15PT	12/14PT	13/16PT	14/12PT	15/11PT	16/10PT
17/7PT	18/13PT	19/8PT	20/9PT	30/13PT	31/15PT
32/16PT	33//17PT	34/18PT	35/19PT	36/20PT	37/21PT
38/22PT	40/23PT				



ST-32023

22PCS - LOCKING WHEEL NUT KEY SET - BMW

- this socket enables you to permit servicing of customer vehicles, even lost the key.
- material: Cr-Mo steel and black oxide finish.
- application for BMW:

1 series F20/F21, 3 series F30/F31, 4 series F32/F34/F36, 5 series F10/F11, 6 series F12/F13 and 7series F01/F02/F04.
- 20pc - wheel nut socket:

#41	#42	#43	#44	#45	#46	#47	#48	#49
#50	#51	#52	#53	#54	#55	#56	#57	#58
#59	#60							



ST-32022

22PCS - LOCKING WHEEL NUT KEY SET - VW

- this socket enables you to permit servicing of customer vehicles, even lost the key.
- material: Cr-Mo steel and black oxide finish.
- application for VW:

Beetle, EOS, Jetta, Passat, Tiguan, Golf / GTI's in the production years 2006~2012.
- 20pc - wheel nut socket:

#521	#522	#523	#524	#525	#526	#527	#528	#529
#530	#531	#532	#533	#534	#535	#536	#537	#538
#539	#540							



ST-32011

20PCS - LOCKING WHEEL NUT KEY SET - VW

- this socket enables you to permit servicing of customer vehicle, even lost the key.
- material: Cr-Mo steel and chrome finish.
- application for VW:
Beetle, EOS, Jetta, Passat, Tiguan, Golf / GTI's in the production years 2006~2012.
- 20pc - wheel lock adaptor:

#521	#522	#523	#524	#525	#526	#527	#528	#529
#530	#531	#532	#533	#534	#535	#536	#537	#538
#539	#540							

ST-32014

20PCS - LOCKING WHEEL NUT KEY SET - AUDI

- this socket enables you to permit servicing of customer vehicles, even lost the key.
- material: Cr-Mo steel and chrome finish.
- application for installing and removing locks of "Audi" only.
- 20pc - wheel lock adaptor:

#801	#802	#803	#804	#805	#806	#807	#808	#809
#810	#811	#812	#813	#814	#815	#816	#817	#818
#819	#820							

ST-32024

22PCS - LOCKING WHEEL NUT KEY SET - AUDI

- this socket enables you to permit servicing of customer vehicles, even lost the key.
- material: Cr-Mo steel and black oxide finish.
- application for audi A6 2005 >.
- 20pc - wheel nut socket:

#A	#B	#C	#E	#F	#G	#H	#I	#J
#L	#M	#N	#P	#Q	#R	#S	#T	#V
#W	#X							

ST-32002

23PCS - LOCKING WHEEL NUT KEY SET - VAG

- this socket enables you to permit servicing of customer vehicle, even lost the key.
- material: Cr-Mo steel and chrome finish.
- application for installing and removing locks of "VAG" only.
- 1pc - 1/2" dr. deep socket x 17 mm.
- 22pc - wheel lock adaptor:

51/6PT	52/7PT	53/8PT	54/9PT	55/10PT	56/11PT
57/12PT	58/13PT	59/14PT	60/15PT	61/16PT	62/17PT
0/10PT.	1/11PT	2/13PT	3/14PT	4/15PT	5/16PT
6/17PT	7/19PT	8/20PT	9/21PT		

ST-32013

20PCS - LOCKING WHEEL NUT KEY SET - PORSCHE

- this socket enables you to permit servicing of customer vehicles, even lost the key.
- material: Cr-Mo steel and chrome finish.
- application for installing and removing locks of "Porsche" only.
- 20pc - wheel lock adaptor:

ABC50	ABC51	ABC52	ABC53	ABC54	ABC55
ABC56	ABC57	ABC58	ABC59	ABC60	ABC61
ABC62	ABC63	ABC64	ABC65	ABC66	ABC67
ABC68	ABC69				



ST-32037

10PCS - LOCKING WHEEL NUT KEY SET - TESLA

- this socket enables you to permit servicing of customer vehicles, even lost the key.
- applicable for installing and removing locks of Tesla series.
- 10pc - wheel lock adaptor:
#76, #77, #78, #79, #80, #81, #82, #83, #84, #85.



ST-32028

16PCS - LOCKING WHEEL NUT REMOVAL SET

- easily remove many popular after-market locking wheel nuts.
- thin wall socket prevents damaging the wheel.
- extra-long wheel nut socket keeps wrench away from the wheel, preventing nick and scratch.
- not available to work with air impact wrench.
- 16pc - wheel nut socket:
 - 5-point spline socket - 18.9mm (id) x 53.4mmL.
 - 6-point spline socket - 16.6mm (id) x 90mmL./18mm (id) x 87.5mmL.
 - 7-point spline socket - 15.6mm (id) x 53.8mmL./17.1mm (id) x 76.1mmL.
 - 7-point spline socket - 18.8mm (id) x 87.6mmL.
 - 12-point spline socket - 17.7mm (id) x 90mmL./15.2mm (id) x 91.5mmL.
 - 3-point triangle socket bit - 12mm (od) x 71.5mmL.
 - 6-point hex. socket bit - 11.8mm (od) x 72.3mmL./14.8mm (od) x 68.3mmL.
 - 6-point hex. socket bit - 14.2mm (od) x 69.6mmL.
 - 8-point star socket bit - 13.5mm (od) x 69.4mmL./10.5mm (od) x 72.3mmL.
 - 9-point tuner nut socket bit - 11.6mm (od) x 70.7mmL.
 - 10-point star socket bit - 13.3mm (od) x 58.9mmL.



ST-32034

11PCS - UNIVERSAL LOCKING WHEEL NUT REMOVAL KIT

- this is very effective and must have owned a workshop tool.
- the tool kit includes shroud which protects the wheel against any damage.
- simple to use master tool kit has the capability of removing practically any locking wheel nuts.
- contents:

1pc - impact driver.	3pc - blade C pack.
1pc - center punch.	1pc - outer shroud
1pc - blade A.	1pc - blade B.
1pc - hand protection ring.	
1pc - main body and outer shroud.	
1pc - 1/2" dr. x 24mm drive impact socket.	



ST-32040

3PCS - LOCKING WHEEL BOLT REMOVAL SET

- fits vehicles equipped with the spinning collar locking wheel bolt.
- to remove the ultra high security locking wheel bolt with spinning collar which is stuck from being over tightened, round, stripped or the key is broken / missing.



ST-32041

4PCS - LOCKING WHEEL BOLT REMOVAL KIT

- M16 x 1.5 with slide hammer.
- fits vehicles equipped with the spinning collar locking wheel bolt.
- to remove the ultra high security locking wheel bolt with spinning collar which is stuck from being over tightened, round, stripped or the key is broken / missing.

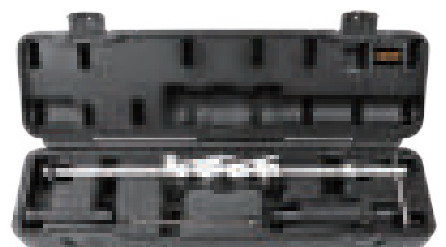

ST-32035

5PCS - 1" DR. BUDD WHEEL NUT REMOVAL SOCKET SET

- extra deep design lets you remove both nut and stud with just one socket.
- operation with 1" square driver wrench.
- hex. 35mm x square 17mm, hex. 38mm x square 20mm, hex. 41mm x square 21mm, for front and rear axle wheel on Isuzu, Hino, Mitsubishi Fuso and import trucks.
- hex. 33mm for mack midliner, Volvo, white and import trucks with dual rear wheels.
- hex. 1-1/2" x square 13/16" for american - made trucks with dual rear wheels.



ST-32036

9PCS - CENTER SLEEVE PIN SET

- design to protect the wheel threads when taking off the wheel.
- center sleeves kit with inner thread.
- contents:
each kit includes 3 sleeves:
M18 x 1.5 - DAF, Unimog, MAN, Renault, Volvo.
M20 x 1.5 - Mercedes Benz.
M22 x 1.5 - DAF, MAN, Mercedes Benz, Ford, Renault, Scania, Volvo.



ST-32001

13PCS - TPMS TOOL ASSORTMENT KIT

- comprehensive tyre pressure monitoring system (TPMS) set that contains tools required to correctly mount the TPMS sensor to the wheel rim.
- 1pc - torque tool for valve and sensor assembly 0.5 ~ 3.5 Nm.
- 1pc - valve insert tool torque: 0.25 Nm.
- 1pc - valve insert tool torque: 0.45 Nm.
- 1pc - grommet removal tool 80 mmL.
- 2pc - 1/4" dr. socket: 11,12 mm x 50 mmL.
- 3pc - 1/4" dr. socket bit: T10 - T15 - T20.
- 1pc - pin punch: 2mm x 150mmL.
- 1pc - torque wrench 2 ~ 14Nm.
- 1pc - bit holder 150mmL.
- 1pc - tyre valve removal tool.



ST-32029

10PCS - TPMS TOOL ASSORTMENT KIT

- comprehensive tyre pressure monitoring system (TPMS) set that contains tools required to correctly mount the TPMS sensor to the wheel rim.
- fixed torque 0.45 Nm for tire valve core.
- adjustable torque: 1.4 / 3.3 / 4 Nm for assembling TPMS.
- TX-bits T10, T15, T20.
- holder thorn: 2 mm.

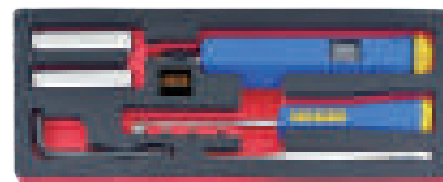

ST-32004

DIGITAL ELECTRONIC TYRE PRESSURE GAUGE

- to measure tyre pressure, measuring range: 5 ~ 150 PSI.
- with LCD backlight, LED light (only use for searching gas vent).
- 4 unit set conversion: PSI, Bar, Kpa, Kg/cm².
- dual powered solar panel and lithium battery.



ST-32033

2 IN 1 TIRE THREAD DEPTH & BRAKE PAD THICKNESS GAUGE

- 2 in 1 function, easy to carry, used for checking thickness of brake pad and depth of tire thread.
- durable, accurate measurement, delicate appearance.
- made of high quality material.
- cable length, 180 x 15 mm.



ST-32006

TYRE LEVER W/PLASTIC PROTECTOR - FLAT TYPE

- with the changeable plastic covering the rim is not damaged if used properly.
- please use necessary in painted or powder-coated wheel!
- flat pattern with hook / taper end.
- tool size: length: 380 mm. / width: 24 mm.



ST-32042

TYRE LEVER W/PLASTIC PROTECTOR - FLAT TYPE

- with the changeable plastic covering the rim is not damaged if used properly.
- please use necessary in painted or powder-coated wheel!
- flat pattern with hook / taper end.
- tool size: length: 500 mm. / width: 27 mm.



ST-32017A

TYRE LEVER - FLAT TYPE

- chrome plated hardened and tempered.
- flat pattern with hook / taper end.
- tool size: length: 380 mm. / width: 23 mm.



ST-32017B

TYRE LEVER - BENT TYPE

- chrome plated hardened and tempered.
- bent pattern with hook / taper end.
- tool size: length: 380 mm. / width: 23 mm.

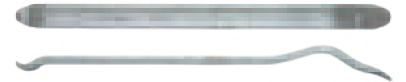

ST-32018A

TYRE LEVER - FLAT TYPE

- chrome plated hardened and tempered.
- flat pattern with hook / taper end.
- tool size: length: 530 mm. / width: 28 mm.



ST-32018B

TYRE LEVER - BENT TYPE

- chrome plated hardened and tempered.
- bent pattern with hook / taper end.
- tool size: length: 530 mm. / width: 28 mm.

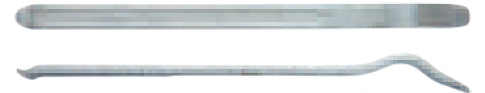

ST-32019A

TYRE LEVER - FLAT TYPE

- chrome plated hardened and tempered.
- flat pattern with hook / taper end.
- tool size: length: 650 mm. / width: 28 mm.



ST-32019B

TYRE LEVER - BENT TYPE

- chrome plated hardened and tempered.
- bent pattern with hook / taper end.
- tool size: length: 650 mm. / width: 28 mm.



ST-32020A

TYRE LEVER - FLAT TYPE

- chrome plated hardened and tempered.
- flat pattern with hook / taper end.
- tool size: length: 400 mm. / width: 23 mm.



ST-32021A

TYRE LEVER - FLAT TYPE

- chrome plated hardened and tempered.
- flat pattern with hook / taper end.
- tool size: length: 600 mm. / width: 28 mm.



ST-32038

FOLDING CROSS LUG WRENCH

- made by heat-treated chrome vanadium steel for strength exceeding international specifications.
- professional plating prevents socket accessories from corrosion.
- easy to fold and unfold.
- space saving and user-friendly.
- overall length: 410 mm.
- available size: 17mm, 19mm, 21mm and 1/2" dr.

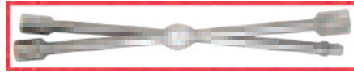

ST-32039

FOLDING CROSS LUG WRENCH

- made by heat-treated chrome vanadium steel for strength exceeding international specifications.
- professional plating prevents socket accessories from corrosion.
- space saving and user-friendly.
- hex. stem overall length: 410 mm.
- steel tube overall length: 360 mm.
- available size: 17mm, 19mm, 21mm, 23mm and 1/2" dr.

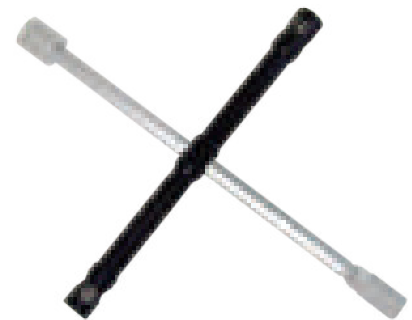
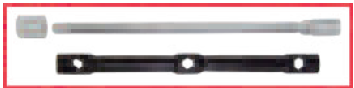

ST-24561

2PCS - RIM PROTECTOR SET

- a set of 2 pieces of tyre rim protectors.
- designed to reduce damage the wheel rims when fitting or removing tyre.
- helps to protect your rims from scuffs and scratches when changing tyre.
- premium plastic construction of the tyre rim protectors makes it durable in use.
- great for many motorcycles & cars tyre repair in the garage or travel use.



ST-32016

WHEEL BALANCER PLIER HAMMER

- wheel weight plier is used to install, remove, or tighten wheel weights on your tyre rims.
- this wheel weight tool features a hammer, pliers, and crimping tool all in one to allow you to strike, pry, and pinch weights into and out of place.
- fits various T type of wheel balancer weights.

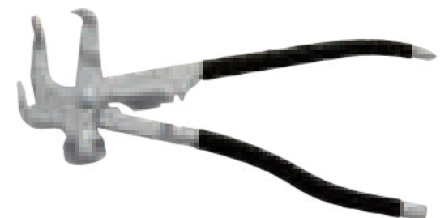

ST-32026

STICK-ON WHEEL BALANCE PLIER HAMMER

- to remove stick-on wheel balancing weight.
- plastic cover on the jaw and hammer can protect the alloy rims from damaging or scratching.
- adjustable jaw for different type of wheel weight.



ST-24551

EXHAUST DONUT STRETCHER

- remove & install rubber mounting ring-style hanger just place the hook of the tool through the rubber mounting ring. then pull or push to stretch until you can remove ring from the hook on muffler, pipe or frame.
- reverse the procedure to install ring.



ST-24562

EXHAUST GROMMET PLIER

- for removal of exhaust component from rubber-style hanger.
- self-location forcing pin.
- 25° offset for easy access.
- "cushioned" slip-resistant handle.



ST-24570

ADJUSTABLE EXHAUST PIPE CUTTER

- suitable for use on exhaust & tailpipe, and thin-wall copper and steel-tubing.
- simply hook in pin to desired diameter, tighten chain by turning adjustable "T" handle during cutting process.
- capacity: up to 2.5mm (thickness) and 8 ~ 90mm (outside dia.).



ST-24658

ADJUSTABLE EXHAUST PIPE CUTTER

- suitable for use on exhaust & tailpipe, and thin-wall copper and steel-tubing.
- simply hook in pin to desired diameter, tighten chain by turning adjustable by hand.
- capacity: up to 2.5mm (thickness) and 19 ~ 83mm (outside dia.).

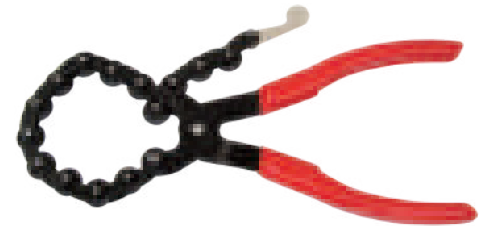

EXHAUST AND TAIL-PIPE CUT-OFF TOOL

ST-24659A capacity: up to 2.5mm (thickness) and 35 ~ 64mm (o.d.).

ST-24659B capacity: up to 2.5mm (thickness) and 50 ~ 83mm (o.d.).

- suitable for use on exhaust & tailpipe, and thin-wall copper and steel-tubing.
- simply hook in pin to desired diameter, tighten chain by turning adjustable handle during cutting process.

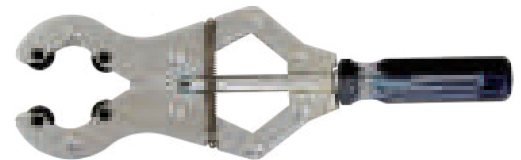

ST-24571

3PCS - EXHAUST TAIL-PIPE EXPANDER SET

- handy set designed to quickly and easily straighten out dents in tailpipe and exhaust pipe.
- fitted with extra long hex bar for easier turning.
- simply insert the tool inside the tailpipe and turn the hex bar to expand the tool inside the pipe.
- capacity: 29 ~ 44, 38 ~ 62, 54 ~ 87mm (dia.).



ST-24571A

EXHAUST TAIL-PIPE EXPANDER

- handy set designed to quickly and easily straighten out dents in tailpipe and exhaust pipe.
- fitted with extra long hex bar for easier turning.
- simply insert the tool inside the tailpipe and turn the hex bar to expand the tool inside the pipe.
- capacity: 29 ~ 44mm. (dia.)



ST-24571B

EXHAUST TAIL-PIPE EXPANDER

- handy set designed to quickly and easily straighten out dents in tailpipe and exhaust pipe.
- fitted with extra long hex bar for easier turning.
- simply insert the tool inside the tailpipe and turn the hex bar to expand the tool inside the pipe.
- capacity: 38 ~ 62mm. (dia.)

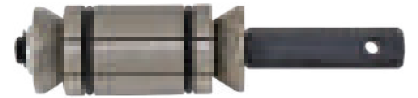

ST-24571C

EXHAUST TAIL-PIPE EXPANDER

- handy set designed to quickly and easily straighten out dents in tailpipe and exhaust pipe.
- fitted with extra long hex bar for easier turning.
- simply insert the tool inside the tailpipe and turn the hex bar to expand the tool inside the pipe.
- capacity: 54 ~ 87mm. (dia.)

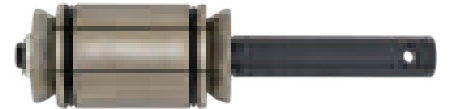

ST-24552

5PCS - EXHAUST REPAIR KIT

- handy set designed to quickly and easily straighten out dents in tailpipe and exhaust pipe.
- especially for exhaust and tailpipe, suited to use on exhaust and tailpipe, and thin-wall copper and steel tubing.
- with this tool kit can easily cut pipes without exerting pripping pressure.
- does it leave burrs, simply hook in pin to desired diameter, tighten chain by turning adjustment T bar handle during cutting process.
- adjustable pipe cutter capacity: 2.5 mm thickness and 60 mm (dia.).
- tailpipe expander capacity: 38 ~ 87mm. (dia.)



ST-24660

7PCS - EXHAUST PIPE STRETCHER KIT

- handy set designed to quickly and easily straighten out dents in tailpipe and exhaust pipe.
- especially for exhaust and tailpipe, suited to use on exhaust and tailpipe, and thin-wall copper and steel tubing.
- expands all types of exhaust pipe, including stainless steel.
- inexpensive alternative to hydraulic pipe expanders.
- capacity: 40 ~ 105mm. (dia.)



ST-24648

3-WAY CATALYTIC CONVERTER CARBON WASHER

- whilst these are a necessary by product of running a combustion engine, can be harmful to the environment, contribute to air pollution and cause health problems for some people.
- diesel vehicles, in particular, are in the spotlight for the emissions they produce as they're seen to be more polluting than petrol cars. as such, vehicle excise duty or vehicle tax is now determined by either engine size or fuel type and CO2 emissions.
- available for most of cars.



ST-29057

13PCS - FUEL TANK LOCKING RING REMOVAL TOOL SET

- suitable for Toyota, Lexus, Scion and Honda vehicles.
- this tool is operation with 1/2" dr. ratchet wrench.
- achieving exactly the right pressure and placement.
- application for Toyota:
4runner / Auris / Avensis / Camry / Celica / Corolla / Crown / Etios / FJ Cruiser / Hiace / Highlander/ Land Cruiser / Lfa / Mark x / Mr2 / Porte / Previa / Prius / Prius C / Ractis / Rav4 / Sai / Tacoma / Vios / Yaris.
- application for Lexus:
ct200h / gs300 / gs350 / gs430 / gs460 / hs250h / is200 / is250 / is350 / ls430 / lx570 / rx200t / rx270 / rx330 / rx350 / rx400h / rx450h.
- application for Scion: im / tc / xa / xb / xd.
- application for Honda: Accord / City / Civic / CRV / Fit / Lengend / Odyssey / type R.



ST-29058

FUEL TANK LOCKING RING REMOVAL TOOL

- suitable for Opel, Gauxhall and Saab vehicles.
- this tool is designed to remove and install the fuel tank locking ring.
- this tool is operation with 1/2" dr. ratchet wrench.
- application for Opel / Gauxhall:
astra-G (1998 ~ 2012) astra-H (2004 ~ 2012)
zafira-A (1998 ~ 2012) zafira-B (2005 ~ 2012)
corsa-C (2001 ~ 2012) vectra-C (2002 ~ 2012)
signum (2003 ~ 2012) tigra-B (2004 ~ 2012)
- application for Saab: 9-3 (2003 ~ 2011)
engine code: B207, B284, D223L, Z19DT, Z19DTH, Z19DTR.



ST-29059

FUEL TANK LOCKING RING REMOVAL TOOL

- suitable for Alfa Romeo, Fiat, Lancia, Ferrari and Maserati vehicles.
- this tool is designed to remove and install the fuel tank locking ring.
- this tool is operated with 1/2" dr. ratchet wrench or 21mm spanner.
- application for Alfa Romeo: GT, 147, 156, 159 and 166.
- application for Fiat: grande punto, idea, linea, multipla, panda, nuova 500, nuova bravo, panda 4x4, punto, sedici, doblo, croma, stilo, ducato, doblo cargo, idea van, grande punto van, multipla van, panda van, stilo van, scudo.
- application for Lancia: y, y psilon, musa, thesis.
- application for Ferrari:
360 spider, 430 coupe, 430 scuderia, 430 scuderia spider 16M, 430 spider, 575 superamerica, 575M maranello, 599 GTB fiorano, 612 scaglietti. Enzo .
- application for Maserati:
4200 coupe, 4200 gransport, 4200 spyder, gran turismo, quattroporte.

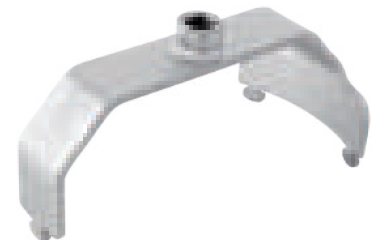
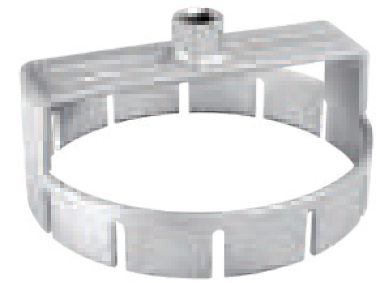

ST-29060

FUEL TANK LOCKING RING REMOVAL TOOL

- this tool is designed to remove and install the fuel tank locking ring.
- this tool is operated with 1/2" dr. ratchet wrench or 21mm spanner.
- application for:
Audi, BMW, Chevrolet, Chrysler, Fiat, Ford, GM, Hyundai, Jaguar, Kia, Land Rover, Mercedes Benz, Nissan, Opel, Vauxhall, Volvo and VW vehicles, etc.....



ST-29061

FUEL TANK LOCKING RING REMOVAL TOOL

- this tool is designed to remove and install the fuel tank locking ring.
- this tool is operated with 1/2" dr. ratchet wrench or 21mm spanner.
- application for:
Peugeot and Citroën vehicles.

ST-29062

FUEL TANK LOCKING RING REMOVAL TOOL

- this tool is designed to remove and install the fuel tank locking ring.
- this tool is operated with 1/2" dr. ratchet wrench or 21mm spanner.
- application for:
Fiat freemont, 500L, 500X.
- application for: Jeep Renegade, etc.....

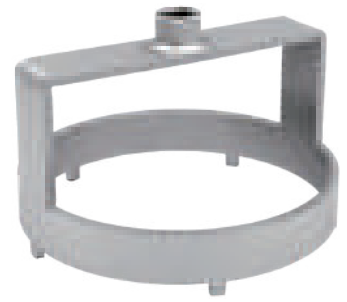

ST-29065

FUEL FEED PIPE PLIER

- aluminum alloy construction profiled head.
- total length: 220 mm.
- to remove and replac of the connections on the in-line fuel filter.
- required when replacing the fuel filter or during engine repair.
- suitable for Alfa, Audi, VW, Fiat, Lancia and Volvo.



ST-29048

5PCS - VAG ASSEMBLY TOOL AND PLASTIC OIL DRAIN PLUGS KIT

- required for proper removing and installing of the special plastic oil drain plug at plastic oil pan.
- application:
VW: golf VII (2013~), jetta hybrid... Audi: A1, A3, A4, A5, Q5 ...
Sköda: octavia 3, superb 3, yeti, rapid... Seat: leon (2013~)...
- contents: 1pc - assembly T-handle.
4pc - plastic oil drain plug.



ST-29044

17PCS - 3/8" DR. OIL DRAIN PLUG KEY SET

- remove and tighten sump plugs including those on VW / Audi vehicles with security nut.
- comprehensive set of chrome vanadium steel keys.
- ideal for removing and tightening different type of sump plugs on engine, gearbox and back axle.
- suitable for use with a 3/8" dr. tool.
- square (S): 8, 9.5, 10, 10.5, 11, 12 and 13.1 mm.
- hex (H): 8, 9, 10, 12, 13, 14 and 17 mm. ● square hole (XS): 10 mm.
- triangle (XT): 10 mm. ● star (M): 16 mm.



ST-29045

64PCS - OIL PAN THREAD REPAIR KIT

- a comprehensive thread repair kit ideal for repairing sump, gearbox and different drain plug thread.
- use tap to slightly enlarge the thread size, to fit a new drain plug and washer.
- contents:
1 x M13 x 1.5 mm tap. 1 x M17 x 1.5 mm tap.
5 x M13 x 1.5mm 17mm sump bolt. 5 x M17 x 1.5 mm 8 mm sump bolt.
10 x washers for M13 bolt. 10 x washers for M17 bolt.
1 x M15x1.5 mm tap. 1 x M20 x 1.5 mm tap.
5 x M15 x 1.5mm 19mm sump bolt. 5 x M20 x 1.5 mm 10 mm sump bolt.
10 x washers for M15 bolt. 10 x washers for M20 bolt.



ST-26005

FLEXIBLE DRAINING PAD

- drain hard-reach oil filter without a mess.
- reshape and reuse thousands of time.
- easy to clean and simple to store.
- material: nitrile rubber with aluminum net.
- size: 170 mm x 370 mm x 3.5 mm (t.).

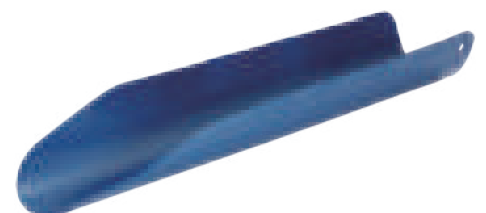

ST-24565

FLUID ROTARY HAND PUMP

- the most worldwide popular pump.
- comes with three suction tube and discharge spout.
- tube size 1" dia.
- non-leak fitting.
- use with: machine oil, lubricant, diesel, kerosene, heating oil, motor oil.



ST-24567

FLUID SIPHON PUMP

- keep squeezing pump vertical at initial extraction to close the check valve.
- press the squeezing pump by hand, the extraction will be executed.
- transferring fuel from car to car.
- extraction fluid from the tank. ● pumping fuel into the heater.

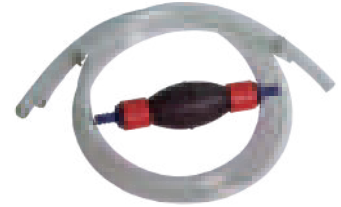

ST-26012

SYRINGE FOR VEHICLE FLUID CHANGE

- transparent design to see fluid visually.
- suitable for fluid suction and supply in vehicle service.
- application such as gear oil and differential fluid.
- composite plastic resists to fluid and antifreeze expect brake oil.
- capacity: 200 c.c.



ST-26013

SYRINGE FOR VEHICLE FLUID CHANGE

- transparent design to see fluid visually.
- suitable for fluid suction and supply in vehicle service.
- application such as gear oil and differential fluid.
- composite plastic resists to fluid and antifreeze expect brake oil.
- capacity: 1.5 litre.



ST-26014

MANUAL OPERATION FLUID EXTRACTOR

- three air outlet with check valve design on handle for easy and quick to release air pressure from the extractor.
- easy to operate suitable for engine oil, gear oil, brake fluid, coolant, water ...
- provide w/new decompression valve for easy to release the negative pressure.
- fixing valve and safety cup for automatic cut-off extracting.
- non-spark, non-power fluid extractor.
- include 3pcs nylon tubes can be extracting and non-corrosive fluid.
- include 1.5 meter silicone hose with one touch controller and universal rubber adapter, can fits to most type brake fitting.
- capacity: 9.5 litre.



ST-25105

MANUAL AND PNEUMATIC FLUID EXTRACTOR

- this machine is designed for the extraction of all type of engine, transmission and lubricating oils from car, motorcycle, marine engine and industrial machinery.
- available with manual or pneumatic operation.
- venturi system design to provide excellent performance.
- suitable also for low viscosity fluid such as water.
- include 4pcs nylon tubes can be extracting and non-corrosive fluid.
- capacity: 9.5 litre.



ST-26001

6.6 L. OIL DRAIN PAN

- the capacity is enough for single oil change.
- hanging hole and back-shelf with protruding stub for draining oil filter.
- dimension: L 435 mm. / W 395 mm. / H 110 mm.
- capacity: 6.6 litre.



ST-26002

8.0 L. OIL DRAIN PAN

- suitable for multiple oil change.
- features anti-splash lip that contains fluid when carrying or pouring.
- large handle and enclosed pouring spout makes easy work of returning oil / fluid to recycling container.
- dimension: L 502 mm. / W 400 mm. / H 132 mm.
- capacity: 8.0 litre.



ST-26003

16 L. OIL DRAIN PAN

- suitable for multiple oil change.
- features anti-splash lip that contains fluid when carrying or pouring.
- large handle and enclosed pouring spout makes easy work of returning oil / fluid to recycling container.
- dimension: L 582 mm. / W 472 mm. / H 156 mm.
- capacity: 16 litre.



ST-26004

24 L. OIL DRAIN PAN

- suitable for multiple oil change.
- features anti-splash lip that contains fluid when carrying or pouring.
- large handle and enclosed pouring spout makes easy work of returning oil / fluid to recycling container.
- dimension: L 820 mm. / W 540 mm. / H 190 mm.
- capacity: 24 litre.



ST-26006

6 L. OIL DRAIN PAN AND RECYCLING STORAGER

- purpose-made for the recovery of oil and antifreeze.
- this pan helps to keep the workshop floor free from oily residue and aid return of oil to recycling containers with min. risk of spill or splash.
- large handle position to aid carrying and pouring.
- resistant to most chemical and solvent.
- dimension: L 427 mm. / W 292 mm. / H 126 mm.
- capacity: 6 litre.



ST-26007

10 L. OIL DRAIN PAN AND RECYCLING STORAGER

- purpose-made for the recovery of oil and antifreeze.
- this pan helps to keep the workshop floor free from oily residue and aid return of oil to recycling containers with min. risk of spill or splash.
- large handle position to aid carrying and pouring.
- resistant to most chemical and solvent.
- dimension: L 567 mm. / W 321 mm. / H 126 mm.
- capacity: 10 litre.

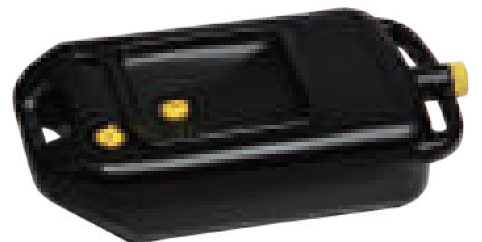

ST-26008

17 L. OIL DRAIN PAN AND RECYCLING STORAGER

- purpose-made for the recovery of oil and antifreeze.
- this pan helps to keep the workshop floor free from oily residue and aid return of oil to recycling containers with min. risk of spill or splash.
- large handle position to aid carrying and pouring.
- resistant to most chemical and solvent.
- dimension: L 671 mm. / W 380 mm. / H 138 mm.
- capacity: 17 litre.



ST-25064

INFRARED THERMOMETER

- non contact thermometer detects the infrared ray that an object emits.
- displays the measurement temperature on the LCD.
- digital readout.
- battery low indicator.
- emissivity point indicator.
- measuring range: $-20^{\circ}\text{C} \sim 500^{\circ}\text{C}$.
- $^{\circ}\text{F}$ & $^{\circ}\text{C}$ selectable.
- distance ratio: 10:1.
- laser indicator.



ST-25077

INFRARED THERMOMETER

- non contact thermometer detects the infrared ray that an object emits.
- displays the measurement temperature on the LCD.
- digital readout.
- battery low indicator.
- emissivity point indicator.
- measuring range: $-50^{\circ}\text{C} \sim 800^{\circ}\text{C}$.
- $^{\circ}\text{F}$ & $^{\circ}\text{C}$ selectable.
- distance ratio: 30:1.
- laser indicator.



ST-27006A

ENDOSCOPE

- this is a very helpful auxiliary tool for technician to visually check equipment.
- this equipment is the extension of eye, it helps user to visualize the place which cannot be reached by eyesight.
- camera resolution: 300K pixel.
- camera diameter: 10.5 mm.
- tube length: 550 mmL.
- build-in 4pcs of LED.
- comes with USB connector.



ST-27006B

ENDOSCOPE

- this is a very helpful auxiliary tool for technician to visually check equipment.
- this equipment is the extension of eye, it helps user to visualize the place which cannot be reached by eyesight.
- camera resolution: 300K pixel.
- camera diameter: 8.0 mm.
- tube length: 1,000 mmL.
- build-in 6pcs of LED.
- come with USB connector.



ST-27003A

TELESCOPING INSPECTION MIRROR

- this inspection mirror is perfect for inspection of the invisible, hard to reach behind view spots and ideal for a visula inspection.
- the mirror is made of clear glass that can be positioned by setting the double all angle ball joints for 360° view.
- telescoping with 5 sections from 160 ~ 640 mmL.
- mirror diameter: 57 mm.



ST-27003B

TELESCOPING INSPECTION MIRROR

- this inspection mirror is perfect for inspection of the invisible, hard to reach behind view spots and ideal for a visula inspection.
- the mirror is made of clear glass that can be positioned by setting the double all angle ball joints for 360° view.
- telescoping with 5 sections from 160 ~ 640 mmL.
- mirror diameter: 83 mm.



ST-27004

TELESCOPING INSPECTION MIRROR

- this inspection mirror is perfect for inspection of the invisible, hard to reach behind view spots and ideal for a visula inspection.
- the mirror is made of clear glass that can be positioned by setting the double all angle ball joints for 360° view.
- telescoping with 5 sections from 160 ~ 640 mmL.
- mirror size: 50 mm x 90 mm.



ST-29033

8 WATT COB LED FLEXIBLE WORK-LIGHT

- body material: plastic nylon + glass fiber.
- battery: 3.7 volt, 2200m/Ah. (Li-ion battery)
- power input: AC100 ~ 240 volt, 50/60Hz.
- power output: 5.0 volt, 1000m/Ah.
- charging time: 3.5 ~ 4.0 hours.
- active time: 4.0 ~ 5.0 hours.
- maximum output: 261 lumen.
- designed with brightness adjusting switch.
- come with 5 volt, 1A. charger and USB cable.
- overall length: 445 mmL.

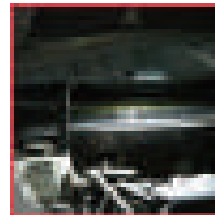

ST-29034

MINI 8 WATT COB LED FLEXIBLE WORK-LIGHT

- body material: plastic nylon + glass fiber.
- battery: 3.7 volt, 2200m/Ah. (Li-ion battery)
- power input: AC100 ~ 240 volt, 50/60Hz.
- power output: 5.0 volt, 1000m/Ah.
- charging time: 3.5 ~ 4.0 hours.
- active time: 4.0 ~ 5.0 hours.
- maximum output: 320 lumen.
- designed with brightness adjusting switch.
- come with 5 volt, 1A. charger and USB cable.
- overall length: 215 mmL.



ST-29035

15 WATT COB LED FLEXIBLE WORK-LIGHT

- body material: plastic nylon + glass fiber.
- battery: 3.7 volt, 2200m/Ah. (Li-ion battery)
- power input: AC100 ~ 240 volt, 50/60Hz.
- power output: 5.0 volt, 1000m/Ah.
- charging time: 3.5 ~ 4.0 hours.
- active time: 2.5 hours.
- maximum output: 409 lumen.
- designed with brightness adjusting switch.
- come with 5 volt, 1A. charger and USB cable.
- overall length: 375 mmL.

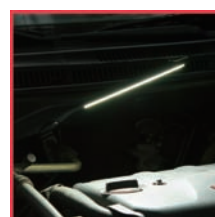

ST-27001

2 IN 1 - LED LIGHTED MAGNETIC PICK-UP TOOL

- perfect for picking up dropped bolt and screw down engine bay and hard to reach place.
- telescoping with 5 sections from 160 ~ 640 mmL.
- maximum pick-up capacity: 1.5 kg.
- powerful magnet: retrieve item in confined area.



ST-27002A

TELESCOPING MAGNETIC PICK-UP TOOL

- perfect for picking up dropped bolt and screw down engine bay and hard to reach place.
- telescoping with 5 sections from 160 ~ 640 mmL.
- powerful magnet: retrieve item in confined area.
- maximum pick-up capacity: 1.5 kg.



ST-27002B

TELESCOPING MAGNETIC PICK-UP TOOL

- perfect for picking up dropped bolt and screw down engine bay and hard to reach place.
- telescoping with 5 sections from 160 ~ 640 mmL.
- powerful magnet: retrieve item in confined area.
- maximum pick-up capacity: 3.5 kg.



ST-27007

2 IN 1 - 4-CLAW AND MAGNETIC PICK-UP TOOL

- perfect for picking up dropped bolt and screw down engine bay and hard to reach place.
- flexible shaft for easy positioning in awkward place.
- maximum pick-up capacity: 0.8 kg.
- strong and powerful 4-claw.
- overall length: 640 mmL

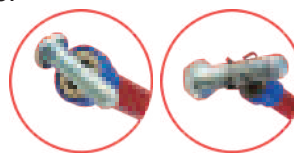

ST-29037

MAGNETIC PARTS TRAY

- tray size: 150 mm (dia.).
- material: stainless steel.
- use for small parts, such as nut, bolt, screw and small tool.
- can be used horizontally, vertically, upside down.



ST-29038

MAGNETIC PARTS TRAY

- tray size: 240 mm x 140 mm.
- material: stainless steel.
- use for small parts, such as nut, bolt, screw and small tool.
- can be used horizontally, vertically, upside down.



ST-29056

EXTRA-LARGE MAGNETIC PARTS TRAY

- tray size: 330 mm x 250 mm.
- material: stainless steel.
- use for small parts, such as nut, bolt, screw and small tool.
- can be used horizontally, vertically, upside down.



ST-29017

UNIVERSAL MAGNETIC PARTS TRAY

- tray size: 150 mm (dia.).
- material: stainless steel.
- designed with nonconductor and adjustment parts holder.
- use for small parts, such as nut, bolt, screw and small tool.
- can be used horizontally, vertically, upside down or hang on hook.



ST-29018

UNIVERSAL MAGNETIC PARTS TRAY

- tray size: 240 mm x 140 mm.
- material: stainless steel.
- designed with nonconductor and adjustment parts holder.
- use for small parts, such as nut, bolt, screw and small tool.
- can be used horizontally, vertically, upside down or hang on hook.



ST-29020

RETRACTABLE MAGNETIC PARTS TRAY

- tray size: 134 x 51 mm (dia.). top x bottom
- depth size: 31 x 90 mmH.
- magnetic base for holding metal part.
- can be used horizontally, vertically, upside down or hang on hook.
- retractable soft-plastic holder for holding non-magnetic parts like stainless, brass or plastic.



ST-29021

RETRACTABLE MAGNETIC PARTS TRAY

- tray size: 225 x 86 mm (dia.). top x bottom
- depth size: 43 x 127 mmH.
- magnetic base for holding metal part.
- can be used horizontally, vertically, upside down or hang on hook.
- retractable soft-plastic holder for holding non-magnetic parts like stainless, brass or plastic.



ST-29022

RETRACTABLE MAGNETIC PARTS TRAY

- tray size: 287 x 185 mm. top x bottom
- depth size: 36 x 70 mmH.
- magnetic base for holding metal part.
- can be used horizontally, vertically, upside down or hang on hook.
- retractable soft-plastic holder for holding non-magnetic parts like stainless, brass or plastic.



ST-28011A

EXTRA-LONG STRAIGHT NOSE PLIER

- drop forged and heat treated steel.
- ideal for using in area with limited access.
- non-slip mat grip handle.
- overall length: 280 mmL.



ST-28011B

EXTRA-LONG 45° BENT NOSE PLIER

- drop forged and heat treated steel.
- ideal for using in area with limited access.
- non-slip mat grip handle.
- overall length: 280 mmL.



ST-31004

INTERNAL LONG-NOSE SNAP RING PLIER

- drop forged and heat treated steel.
- ideal for using in area with limited access.
- internal function.
- non-slip mat grip handle.
- overall length: 225 mmL.
- tip diameter: 1.2 mm.

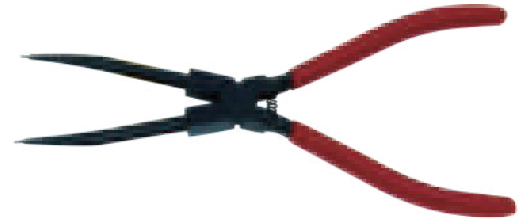

ST-31005

INTERNAL 90° BENT-SNAP RING PLIER

- ideal for using in area with limited access.
- drop forged and heat treated steel.
- internal function.
- non-slip mat grip handle.
- overall length: 215 mmL.
- tip diameter: 1.2 mm.



ST-31006

EXTERNAL LONG-NOSE SNAP RING PLIER

- ideal for using in area with limited access.
- drop forged and heat treated steel.
- external function.
- non-slip mat grip handle.
- overall length: 225 mmL.
- tip diameter: 1.2 mm.

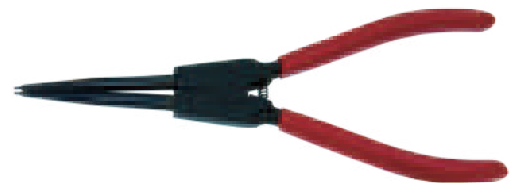

ST-31007

EXTERNAL 90° BENT-SNAP RING PLIER

- ideal for using in area with limited access.
- drop forged and heat treated steel.
- external function.
- non-slip mat grip handle.
- overall length: 215 mmL.
- tip diameter: 1.2 mm.



ST-29031

RATCHET EXTENSION DRIVE BAR

- enables easier work in confined space, such as water pump, power steering pump and transmission.
- provided with two square drive adaptors in 1/4" and 3/8" sq.
- chain-driven mechanism enhances working durability and smooth.
- use a standard wrench to loose the fastener.
- use a standard wrench to tighten the fastener with adequate torque.



ST-23029

10PCS - INTERNAL / EXTERNAL SNAP RING PLIER SET

- replaceable points and spring ratchet locking mechanism to securely hold against tension.
- internal: 78 mm ~ 158 mm (dia.).
- external: 88 mm ~ 165 mm (dia.).
- tip: 3 mm (dia.).
- length: 400 mmL.
- spread: 85 mm.



460mmL. INDUSTRIAL LEVER RIVETER

ST-29010A	capacity: 2.4 mm. / 3.2 mm. / 4.0 mm. / 4.8 mm.(dia.)
ST-29010B	capacity: 3.2 mm. / 4.0 mm. / 4.8 mm. / 6.4 mm.(dia.)

- suitable for construction and industrial application.
- gives large riveting force.
- aluminum body, steel tube with rubber handle.

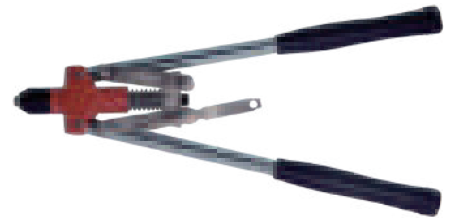

250mmL. TIN SNIP CUTTING

ST-29023A	250 mmL. - right cutting.
ST-29023B	250 mmL. - left cutting.
ST-29023C	250 mmL. - straight cutting.

- drop forged, chrome-vanadium steel.
- heavy duty mold suitable for sheet metal.
- cutting capacity: 1.5 mm thickness steel.
- high twisting force.
- curved blades.



ST-29036A
12" BOLT CUTTER

- overall length: 300 mmL.
- capacity: 5 mm. diameter.

ST-29036E
30" BOLT CUTTER

- overall length: 750 mmL.
- capacity: 13 mm. diameter.

ST-29036B
14" BOLT CUTTER

- overall length: 350 mmL.
- capacity: 7 mm. diameter.

ST-29036F
36" BOLT CUTTER

- overall length: 900 mmL.
- capacity: 16 mm. diameter.

ST-29036C
18" BOLT CUTTER

- overall length: 450 mmL.
- capacity: 8 mm. diameter.

ST-29036G
42" BOLT CUTTER

- overall length: 1,050 mmL.
- capacity: 18 mm. diameter.

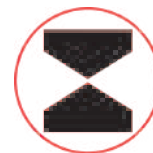
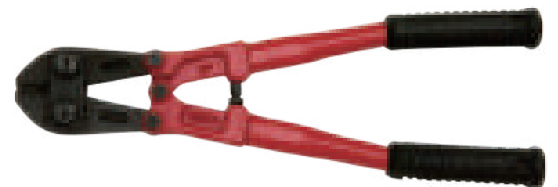

ST-29036D
24" BOLT CUTTER

- overall length: 600 mmL.
- capacity: 10 mm. diameter.

ST-29026B
16PCS - IMPACT DRIVER SET

- the original use of the term applied to a sturdy, hand held, metal barrel shaped device, that was designed to loose (or tight) stubborn screws.
- it achieves by being clobbered with a hammer - each blow turning the holder, a small fraction of a rotation.
- 1pc - impact driver.
- 2pc - slotted bit: 8, 10mm.
- 2pc - pozidrive bit: PZ2, PZ3.
- 5pc - star bit: T25, T30, T40, T45, T50.
- 3pc - hex bit: 6, 8, 10mm.
- 2pc - phillips bit: PH2, PH3.
- 1pc - 1/4" dr. adaptor.



NUT SPLITTER

ST-24009A	capacity: 3 ~ 12 mm.
ST-24009B	capacity: 12 ~ 17 mm.
ST-24009C	capacity: 17 ~ 25 mm.
ST-24009D	capacity: 25 ~ 32 mm.

- for the safe removal of corroded or damaged nuts without damaging bolt threads.
- drop forged steel body hardened and tempered with chrome plated.
- threaded splitting pin manufactured from chrome vanadium steel with black phosphate finish.
- a few turns with a spanner & the hardened steel chisel soon slices through.

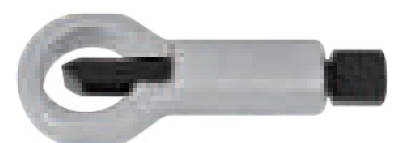

ST-24014

8PCS - STUD EXTRACTOR BIT SET

- designed with the following features to remove objects easily: star plus tip, tapered head, twisted body and strong teeth.
- for removing a worn, rusty or broken stud with: internal star, internal star plus, internal star security, internal round and internal hex.
- contents:
shank hex. 10mm: 3.4~4.67mm, 4.3~5.92mm, 5.3~7.04mm, 6.35~8.16mm.
shank hex. 12mm: 7.4~9.29mm, 8.4~10.41mm.
shank hex. 14mm: 10.4~12.66mm, 12.4~14mm.
- **product not designed for air impact wrench operation.**

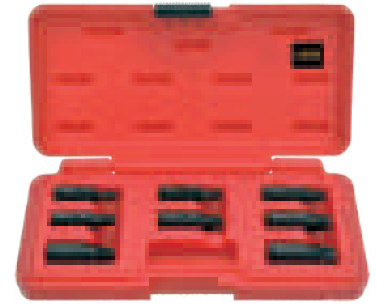

ST-24015

6PCS - 3/8" DR. BOLT EXTRACTOR SET

- set designed for removing worn or rusty inner hex bolt by drilling a hole.
- suitable for using with 3/8" dr. ratchet handle.
- contents: 2 - 3 - 4 - 6 - 8 - 10mm x 60mmL.
- **product not designed for air impact wrench operation.**

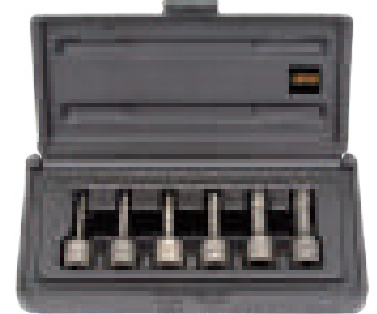

ST-24016

5PCS - 1/2" DR. BOLT EXTRACTOR SET

- set designed for removing worn or rusty inner hex bolt by drilling a hole.
- suitable for using with 1/2" dr. ratchet handle.
- contents: 8 - 10 - 12 - 14 - 16mm x 78mmL.
- **product not designed for air impact wrench operation.**



ST-24017

9PCS - 3/8" DR. TWIST SOCKET SET

- set designed for removing damaged nut and bolt.
- reverse spiral flutes are designed for maximum grip.
- suitable for using with 3/8" dr. ratchet handle.
- contents: 10 - 11 - 12 - 13 - 14 - 15 - 16 - 17 - 19mm x 32mmL.
- **product not designed for air impact wrench operation.**

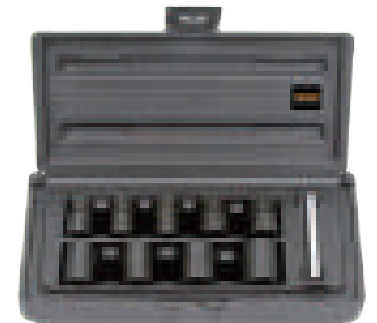

ST-24018

4PCS - 1/2" DR. TWIST SOCKET SET

- set designed for removing damaged nut and bolt.
- reverse spiral flutes are designed for maximum grip.
- suitable for using with 1/2" dr. ratchet handle.
- contents: 17 - 19 - 21 - 22mm x 50mmL.
- **product not designed for air impact wrench operation.**



ST-24019

9PCS - 1/2" DR. TWIST SOCKET SET

- set designed for removing damaged nut and bolt.
- reverse spiral flutes are designed for maximum grip.
- suitable for using with 1/2" dr. ratchet handle.
- contents: 10 - 11 - 12 - 13 - 14 - 15 - 16 - 17 - 19mm x 32mmL.
- **product not designed for air impact wrench operation.**



ST-24020

13PCS - 1/4" & 1/2" DR. TWIST SOCKET SET

- set designed for removing damaged nut and bolt.
- reverse spiral flutes are designed for maximum grip.
- suitable for using with 1/4" or 1/2" dr. ratchet handle.
- contents: 6pc - 1/4" dr.:
6 - 8 - 10 - 11 - 12 - 13mm x 32mmL.
- 7pc - 1/2" dr.:
14 - 16 - 17 - 19 - 21 - 24 - 27mm x 50mmL.
- **product not designed for air impact wrench operation.**



ST-24021

10PCS - 3/8" & 1/2" DR. TWIST SOCKET SET

- set designed for removing damaged nut and bolt.
- reverse spiral flutes are designed for maximum grip.
- suitable for using with 3/8" or 1/2" dr. ratchet handle.
- contents: 4pc - 3/8" dr.:
8 - 10 - 12 - 13mm x 32mmL.
- 6pc - 1/2" dr.:
14 - 15 - 16 - 17 - 19 - 21mm x 50mmL.
- **product not designed for air impact wrench operation.**



ST-24025

9PCS - 3/8" & 1/2" DR. SCREW NUT EXTRACTOR SET

- set for removing worn or rusty inner hex bolt by drilling a hole.
- tool with square drive to work with a ratchet wrench for additional torque.
- suitable for using with 3/8" or 1/2" dr. ratchet handle.
- suitable for using with 17 or 22 mm spanner.
- contents: 6pc - 3/8" dr.:
2 - 3 - 4 - 5 - 6 - 7mm x 45mmL.
- 3pc - 1/2" dr.:
8 - 10 - 12mm x 62.5mmL.
- **product not designed for air impact wrench operation.**



ST-24026

15PCS - HEX DRIVER SCREW NUT EXTRACTOR SET

- set for removing worn or rusty inner hex bolt by drilling a hole.
- tool with square drive to work with a ratchet wrench for additional torque.
- suitable for using with 10 or 12 mm spanner.
- contents:
11pc - hex 12mm:
3 - 4 - 5 - 5.5 - 6 - 8 - 10 mm - 1/8" - 3/16" - 1/4" - 3/8" x 29mmL.
- 4pc - hex 16mm:
11 - 12 - 1/2" - 14mm x 29mmL.
- **product not designed for air impact wrench operation.**



ST-24029

4PCS - 1/4" DR. STUD PULLER SOCKET SET

- function: screw without head; screw up; pull up.
- advantage: quick function and no damage to stud.
- ways in use: put stud puller socket on screw, then handle on it; turn it up or down.
- 4 pc - 1/4" dr.: 2.5, 3, 3.5, 4mm.
suitable for using 1/4" dr. ratchet handle or 12mm spanner.
- **product not designed for air impact wrench operation.**

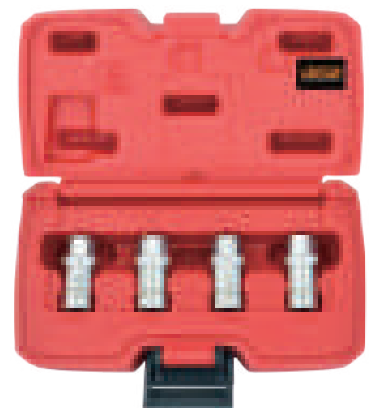

ST-24030

4PCS - 3/8" AND 1/2" DR. STUD PULLER SOCKET SET

- function: screw without head; screw up; pull up.
- advantage: quick function and no damage to stud.
- ways in use: put stud puller socket on screw, then handle on it; turn it up or down.
- 2pc - 3/8" dr.: 6, 8mm.
suitable for using 3/8" dr. ratchet handle or 19mm spanner.
- 2pc - 1/2" dr.: 10, 12mm.
suitable for using 1/2" dr. ratchet handle or 22mm spanner.
- **product not designed for air impact wrench operation.**

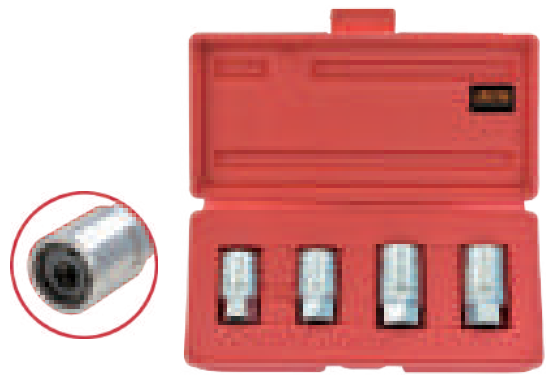

ST-24031

4PCS - 1/2" DR. STUD PULLER SOCKET SET

- function: screw without head; screw up; pull up.
- advantage: quick function and no damage to stud.
- ways in use: put stud puller socket on screw, then handle on it; turn it up or down.
- 4pc - 1/2" dr.: 6, 8, 10, 12mm.
suitable for using 1/2" dr. ratchet handle or 21mm spanner.
- **product not designed for air impact wrench operation.**

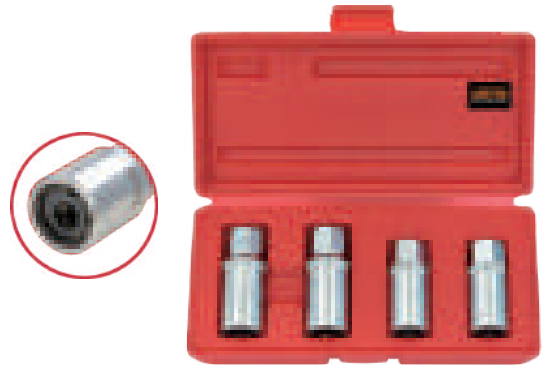

ST-24032

7PCS - 3/8" AND 1/2" DR. STUD PULLER SOCKET SET

- function: screw without head; screw up; pull up.
- advantage: quick function and no damage to stud.
- ways in use: put stud puller socket on screw, then handle on it; turn it up or down.
- 1pc - 3/8" dr.: 5mm.
suitable for using 3/8" dr. ratchet handle or 19mm spanner.
- 6pc - 1/2" dr.: 6, 7, 8, 10, 12, 14mm..
suitable for using 1/2" dr. ratchet handle or 21mm spanner.
- **product not designed for air impact wrench operation.**



AIR HOSE ADAPTOR CLAMP PLIER

ST-24011A available with 6 mm, 8 mm, 10 mm, 12 mm, 16 mm. (o.d.)

ST-24011B available with 7 mm, 9 mm, 10 mm, 12 mm, 14 mm. (o.d.)

ST-24011C available with 8 mm, 9 mm, 10 mm, 11 mm, 12 mm. (o.d.)

ST-24011D available with 15 mm, 16 mm, 18 mm. (o.d.)

- grip the plastic tube, let the copper coupler can put into the tube easily.
- available for air tools, truck, trailer and bus....



ST-24028

9PCS - 1/4" DR. CROWFOOT WRENCH SET

- this tool set is designed for using on hard to reach, confined spaces.
- adaptor to low torque applications.
- contents:
7pc - 7, 8, 10, 11, 12, 13, 14mm. open-end wrench.
1pc - 1/4" dr. x 75mmL. extensions bar.
1pc - 1/4" dr. x 145mmL. breaker bar.



Item No.	Page
ST-21001	167
ST-21002	167
ST-21003	167
ST-22001	124
ST-22002	124
ST-22003	188
ST-22004	188
ST-22005	137
ST-22006	137
ST-22010	133
ST-22011	178
ST-22012	178
ST-22013	134
ST-22013A	134
ST-22013B	134
ST-22013C	135
ST-22013D	135
ST-22013E	135
ST-22013F	135
ST-22014	129
ST-22015	131
ST-22016	127
ST-22026	130
ST-22030	133
ST-22031	133
ST-22035	129
ST-22036	129
ST-22037	132
ST-22038	133
ST-22039	129
ST-22039A	130
ST-22039B	130
ST-22039C	130
ST-22039D	130
ST-22041A	130
ST-22042	132
ST-22043	125
ST-22046	124
ST-22047	131
ST-22048	125
ST-22049	139
ST-22051	131
ST-22052	139
ST-22053	139
ST-22055	138
ST-22056	132
ST-22057	188
ST-22058	138
ST-22059	125
ST-22060	126
ST-22061	126
ST-22062	126
ST-22063	130
ST-22064	132
ST-22065	124

Item No.	Page
ST-22066	132
ST-22067	138
ST-22068	138
ST-22069	131
ST-22070	124
ST-22071	124
ST-22072	125
ST-22073	125
ST-22074	125
ST-22075	133
ST-22076	137
ST-22077	137
ST-22078	129
ST-22079	131
ST-22080	138
ST-22081	137
ST-22082	133
ST-22083	139
ST-22084	132
ST-22086	132
ST-22087	134
ST-22088	139
ST-23004	143
ST-23005	143
ST-23007	143
ST-23008	156
ST-23010	142
ST-23011	143
ST-23014	149
ST-23015	145
ST-23016	194
ST-23017	152
ST-23020	155
ST-23022	159
ST-23023	147
ST-23025	154
ST-23027	154
ST-23028	140
ST-23029	217
ST-23030	140
ST-23030A	140
ST-23030B	140
ST-23030C	140
ST-23031	159
ST-23033A	154
ST-23033B	154
ST-23033C	154
ST-23033D	154
ST-23033E	154
ST-23033F	154
ST-23033G	154
ST-23034A	149
ST-23034B	149
ST-23034C	149
ST-23034D	149

Item No.	Page
ST-23036	149
ST-23038	143
ST-23040	193
ST-23041	193
ST-23046	144
ST-23048	194
ST-23050	145
ST-23051	158
ST-23053A	158
ST-23054	143
ST-23055	158
ST-23056	154
ST-23057	147
ST-23058	141
ST-23059	177
ST-23060	140
ST-23061	140
ST-23061A	140
ST-23061B	140
ST-23061C	140
ST-23063	140
ST-23064	147
ST-23065	157
ST-23066	157
ST-23068	150
ST-23069	151
ST-23070	153
ST-23071	149
ST-23072	156
ST-23073	157
ST-23074	157
ST-23075	146
ST-23076	144
ST-23077	152
ST-23078	145
ST-23079	142
ST-23080	156
ST-23081	146
ST-23082	157
ST-23083	141
ST-23084	141
ST-23085	141
ST-23086	141
ST-23087	148
ST-23088	147
ST-23089	157
ST-23090	152
ST-23091	152
ST-23092	144
ST-23093	146
ST-23094	146
ST-23095	150
ST-23096	150
ST-23097	151
ST-23098	148

Item No.	Page
ST-23099	148
ST-23100	153
ST-23101	144
ST-23102	144
ST-23103	152
ST-23104	156
ST-23105	148
ST-23106	149
ST-23107	148
ST-23108	151
ST-23109	151
ST-23110	151
ST-23111	156
ST-23112	158
ST-23113	153
ST-23114	153
ST-23115	153
ST-23116	153
ST-23117	145
ST-24001	173
ST-24003	173
ST-24004	174
ST-24005	159
ST-24006	170
ST-24007	173
ST-24008	166
ST-24009	215
ST-24009A	218
ST-24009B	218
ST-24009C	218
ST-24009D	218
ST-24010	219
ST-24011A	222
ST-24011B	222
ST-24011C	222
ST-24011D	222
ST-24012	134
ST-24013	219
ST-24014	220
ST-24015	220
ST-24016	220
ST-24017	220
ST-24018	220
ST-24019	220
ST-24020	221
ST-24021	221
ST-24022	189
ST-24023	189
ST-24024	196
ST-24025	221
ST-24026	221
ST-24027	170
ST-24028	222
ST-24029	221
ST-24030	222

Item No.	Page
ST-24031	222
ST-24032	222
ST-24033	189
ST-24034	196
ST-24503	189
ST-24504	190
ST-24506	186
ST-24507	181
ST-24508	184
ST-24510	219
ST-24511	187
ST-24512	187
ST-24513	186
ST-24514	186
ST-24515	187
ST-24516	187
ST-24518	182
ST-24521	182
ST-24522	155
ST-24523	147
ST-24524	128
ST-24525	159
ST-24526	181
ST-24528	178
ST-24529	178
ST-24530	178
ST-24531	179
ST-24532	179
ST-24533	179
ST-24534	179
ST-24535	179
ST-24536	179
ST-24537	179
ST-24538	180
ST-24539	180
ST-24540	180
ST-24542	180
ST-24543	182
ST-24544	183
ST-24546	183
ST-24547	177
ST-24548A	169
ST-24548B	169
ST-24550A	169
ST-24550B	169
ST-24550C	169
ST-24551	207
ST-24552	208
ST-24553	169
ST-24555	155
ST-24556	181
ST-24557	181
ST-24558	177
ST-24559	197
ST-24560	177

Item No.	Page
ST-24561	206
ST-24562	207
ST-24563	170
ST-24564	170
ST-24565	211
ST-24567	211
ST-24568	142
ST-24569	190
ST-24570	207
ST-24571	207
ST-24571A	27
ST-24571B	208
ST-24571C	208
ST-24572	180
ST-24573	155
ST-24574	169
ST-24578	181
ST-24579	180
ST-24580	180
ST-24581	191
ST-24582	190
ST-24583	190
ST-24584	184
ST-24585	170
ST-24586	170
ST-24587	171
ST-24588	171
ST-24589	171
ST-24590	171
ST-24591	171
ST-24592	171
ST-24593	172
ST-24594	172
ST-24595	172
ST-24596	172
ST-24597	191
ST-24598	191
ST-24599	191
ST-24600A	169
ST-24600B	169
ST-24600C	169
ST-24600D	169
ST-24601A	185
ST-24601B	185
ST-24601C	185
ST-24601D	185
ST-24602A	185
ST-24602B	185
ST-24602C	185
ST-24602D	185
ST-24603A	185
ST-24604A	185
ST-24605A	186
ST-24605B	186
ST-24605C	186

Item No.	Page
ST-24605D	186
ST-24605E	186
ST-24605F	186
ST-24606	197
ST-24607	198
ST-24608	198
ST-24609	198
ST-24610	198
ST-24611	199
ST-24612	199
ST-24613	177
ST-24614	181
ST-24615	176
ST-24616	197
ST-24617A	186
ST-24617B	186
ST-24618	191
ST-24619	194
ST-24620	195
ST-24621	190
ST-24622	195
ST-24623	172
ST-24624	199
ST-24625	195
ST-24626	197
ST-24627	197
ST-24628	196
ST-24629	141
ST-24630	176
ST-24631	182
ST-24632	183
ST-24633	197
ST-24634A	185
ST-24634B	185
ST-24634C	185
ST-24634D	185
ST-24635	142
ST-24636	198
ST-24637	181
ST-24638	177
ST-24639	192
ST-24640	192
ST-24641	192
ST-24642	194
ST-24643	159
ST-24644	160
ST-24645	176
ST-24646	142
ST-24647	192
ST-24648	208
ST-24649	195
ST-24650	183
ST-24651	176
ST-24652	176
ST-24653	182

Item No.	Page
ST-24654A	169
ST-24654B	169
ST-24655A	169
ST-24655B	139
ST-24656	184
ST-24657	184
ST-24658	207
ST-24659A	207
ST-24659B	207
ST-24660	208
ST-24661	173
ST-24662	177
ST-24663	176
ST-24664	170
ST-24665	147
ST-24666	182
ST-24667	191
ST-25001	126
ST-25004	126
ST-25007	168
ST-25008	168
ST-25009	165
ST-25020	164
ST-25022B	165
ST-25025	149
ST-25036	154
ST-25037	150
ST-25038	155
ST-25039	155
ST-25040	155
ST-25041	158
ST-25042	184
ST-25047	165
ST-25048	163
ST-25049	166
ST-25050	142
ST-25054	163
ST-25055	166
ST-25056	163
ST-25061	165
ST-25062	167
ST-25063	164
ST-25064	213
ST-25065	166
ST-25066	166
ST-25067	167
ST-25068	163
ST-25069	167
ST-25070A	166
ST-25070B	166
ST-25071	165
ST-25072	163
ST-25073	163
ST-25074	166
ST-25075	184

Item No.	Page
ST-25076	168
ST-25077	213
ST-25079	127
ST-25080	128
ST-25081A	126
ST-25081B	126
ST-25081C	126
ST-25082	127
ST-25083	167
ST-25084	158
ST-25085	128
ST-25086	175
ST-25087	164
ST-25088	164
ST-25089	164
ST-25090	168
ST-25091	168
ST-25092	128
ST-25101	154
ST-25102	189
ST-25103	193
ST-25104	193
ST-25105	211
ST-25108	196
ST-25109	196
ST-25110	196
ST-25111	165
ST-25112	195
ST-25113	193
ST-25114	193
ST-25115	194
ST-25116	168
ST-25517	175
ST-25518	175
ST-25519	175
ST-25520	175
ST-25501	187
ST-25502	162
ST-25508	188
ST-25517	175
ST-26001	211
ST-26002	212
ST-26003	212
ST-26004	212
ST-26005	210
ST-26006	212
ST-26007	212
ST-26008	212
ST-26012	211
ST-26013	211
ST-26014	211
ST-27001	215
ST-27002A	215
ST-27002B	215
ST-27003A	213

Item No.	Page
ST-27003B	214
ST-27004	214
ST-27006A	213
ST-27006B	213
ST-27007	215
ST-28001A	135
ST-28001B	135
ST-28001C	135
ST-28004A	135
ST-28004B	135
ST-28006	136
ST-28007A	136
ST-28007B	136
ST-28007C	136
ST-28007D	136
ST-28009A	136
ST-28009B	136
ST-28010A	136
ST-28010B	136
ST-28011A	217
ST-28011B	217
ST-28013A	136
ST-28013B	136
ST-28013C	136
ST-28013D	136
ST-28014	138
ST-28015	138
ST-28016	138
ST-28017	136
ST-29002	161
ST-29008	191
ST-29010A	218
ST-29010B	218
ST-29012	161
ST-29015	188
ST-29017	216
ST-29018	216
ST-29020	216
ST-29021	216
ST-29022	216
ST-29023A	218
ST-29023B	218
ST-29023C	218
ST-29026B	218
ST-29027	162
ST-29030	154
ST-29031	217
ST-29033	214
ST-29034	214
ST-29035	214
ST-29036A	218
ST-29036B	218
ST-29036C	218
ST-29036D	218
ST-29036E	218

Item No.	Page
ST-29036F	218
ST-29036G	218
ST-29037	215
ST-29038	215
ST-29039	162
ST-29040	162
ST-29041	162
ST-29043	162
ST-29044	210
ST-29045	210
ST-29046	161
ST-29047	161
ST-29048	210
ST-29049A	136
ST-29049B	136
ST-29050	160
ST-29051	160
ST-29052	160
ST-29053	160
ST-29054	160
ST-29055	161
ST-29056	216
ST-29057	209
ST-29058	209
ST-29059	209
ST-29060	209
ST-29061	209
ST-29062	210
ST-29063	161
ST-29065	210
ST-31004	217
ST-31005	217
ST-31006	217
ST-31007	217
ST-32001	204
ST-32002	202
ST-32003	200
ST-32004	204
ST-32006	205
ST-32007	199
ST-32008	199
ST-32009	201
ST-32010	201
ST-32011	202
ST-32012	201
ST-32013	202
ST-32014	202
ST-32015	200
ST-32016	206
ST-32017A	205
ST-32017B	205
ST-32018A	205
ST-32018B	205
ST-32019A	205
ST-32019B	205

Item No.	Page
ST-32020A	206
ST-32021A	206
ST-32022	201
ST-32023	201
ST-32024	202
ST-32025	200
ST-32026	206
ST-32027	200
ST-32028	203
ST-32029	204
ST-32030	200
ST-32031	200
ST-32033	204
ST-32034	203
ST-32035	204
ST-32036	204
ST-32037	203
ST-32038	206
ST-32039	206
ST-32040	203
ST-32041	203
ST-32042	205

LENGTH		
1 FT	=	12 IN
1 IN	=	2.54 CM
1u	=	0.001 CM
1 MM	=	0.1 CM
1 CM	=	0.01 M
1 M	=	39.3701 IN
1 M	=	3.28084 FT
1 CM	=	0.3937 IN
1 MM	=	0.03937 IN

POWER		
1 KPM/S	=	9.8065 W
1 KCAL/S	=	4.1868 KW
1 KCAS/G	=	1.163 W
1 HK	=	735.499 W
1 HP	=	745.7 W
1 KW	=	101.972 KPM/S
1 KW	=	0.238846 KCAL/S
1 KW	=	859.845 KCAL/H
1 KW	=	1.35962 HK
1 KW	=	1.34102 HP

WEIGHT		
1 LB	=	0.453592 KG
1 KG	=	2.20462 LB

TORQUE		
1 FT/LB	=	1.35582NM
1 FT/LB	=	0.138 KG/M
1 NM	=	0.737562 FT/LB
1 NM	=	0.101972 KPM
1 KPM	=	9.80665 NM
1 KG/M	=	9.8 NM
1 KG/M	=	7.23314 FT/LB

PRESSURE		
1 PSI	=	0.07031 KGF/CM ²
1 PSI	=	0.06895 BAR
1 PSI	=	6895 PA
1 PSI	=	6.89476 KPA
1 PSI	=	51.7157 TORR
1 KPA	=	0.01 BAR
1 KPA	=	0.010972 KP/CM ²
1 KPA	=	0.145038 PSI
1 KP/CM ²	=	98.0665 KPA

FLOW		
1 CFM	=	0.471947 L/S
1 CFM	=	0.0283 M ³ /MIN
1 L/S	=	2.1189 CFM
1 M ³ /HR	=	0.277778 L/S
1 M ³ /HR	=	35.317 FT ³ /HR
1 M ³ /HR	=	1000.08 L/S
1 FT ³ /HR	=	0.02832 M ³ /HR
1 M ³ /MIN	=	16.668 L/S
1 M ³ /MIN	=	35.335 CFM

